

ZGM-6-5H | ZGHS | ZGCM-48 | ZGCM-66 | ZGCM-HSA

Floor & Ceiling Mounted Units

Installation Guide for TIDI® Products Authorized Installers Only

Table of Contents

- Important Information** 6
 - Read this Manual Before Starting to Work! 6
 - Zero-Gravity Document List 6
 - Installation Instructions 7
 - Intended Use 8
 - Zero-Gravity® Radiation Protection System 8
 - Foreseeable Misuse 8
 - Safety Liability 8
 - Safety Warning 9
 - Installation Guide 9
 - Pre-Installation Responsibilities 9
- System Description** 10
 - Zero-Gravity Floor Unit (ZGM-6-5H) 10
 - Zero-Gravity Hinged Swing Arm Unit (ZGHSA) 10
 - Zero-Gravity Monorail Hinged Swing Arm (ZGCM-HSA) 11
 - Zero-Gravity Monorail Unit (ZGCM-48 or ZGCM-66) 11
- Safety Symbols** 12
 - Document Safety Symbols 13
 - Device Safety Symbols 17
 - Device Operation Symbols 19
- Body Shield Overview** 21
 - Figure 1 21
 - Figure 1 Chart 22
- System Overview** 23
 - Figure 2 (ZGM-6-5H) 23
 - Figure 2 Chart (ZGM-6-5H) 24
 - Figure 2 Chart (ZGM-6-5H) 25
 - Figure 2 – Other Considerations (ZGM-6-5H) 26
 - Figure 3 (ZGHSA) 27
 - Figure 3 Chart (ZGHSA) 28
 - Figure 3 Chart (ZGHSA) 29
 - Figure 3 – Other Considerations (ZGHSA) 30
 - Figure 4 (ZGCM-48 | ZGCM-66) 31
 - Figure 4 Chart (ZGCM-48 | ZGCM-66) 32
 - Figure 4 Chart (ZGCM-48 | ZGCM-66) 34
 - Figure 4 – Other Considerations (ZGCM-48 | ZGCM-66) 35
 - Figure 5 (ZGCM-HSA) 36
 - Figure 5 Chart (ZGCM-HSA) 37
 - Figure 5 Chart (ZGCM-HSA) 38
 - Figure 5 – Other Considerations (ZGCM-HSA) 39
- Installation Tools** 40
 - Suggested Installation Tools (ZGM-6-5H) 40
 - Required Installation Tools – Ceiling Mounted Unit (ZGHSA | ZGCM-HSA | ZGCM-48 | ZGCM-66) 40
 - Additional Required Installation Tools (ZGHSA) 41

Additional Required Installation Tools (ZGCM-48 ZGCM-66)	41
Additional Required Installation Tools (ZGCM-HSA)	41
Installation – Floor Unit (ZGM-6-5H)	42
System Installation Sequence	42
Relocate All Components to Surgical Suite (Figure 6)	42
Figure 6	43
Install the Boom	44
Figure 7	44
Figure 8	45
Figure 9	46
Install Docking Station	47
Figure 10	47
Install Balancer	48
Figure 11	48
Install End Cap	49
Figure 12	49
Install Body Shield Assembly	50
Figure 13	50
Figure 14	51
Attach Shoulder Shields	52
Figure 15	52
Adjust Balancer	52
Figure 16	53
Balancer Installation Safety	53
Option: Balancer Installation with Locked Cables	53
Release Locked Balancer	54
Figure 17	54
Finalize the Installation	55
Figure 18	55
Installation – Ceiling Mounted Unit (ZGHSA ZGCM-48 ZGCM-66 ZGCM-HSA)	56
System Installation Sequence (ZGHSA)	56
System Installation Sequence (ZGCM-48 ZGCM-66)	56
System Installation Sequence (ZGCM-HSA)	56
Relocate All Components to Surgical Suite (ZGHSA ZGCM-48 ZGCM-66 ZGCM-HSA)	57
Install Hinged Swing Arm Assembly (ZGHSA)	58
Figure 19	60
Figure 20	61
Figure 21	62
Install Rail (ZGCM-48 ZGCM-66 ZGCM-HSA)	63
Figure 22	64
Install Drop Tube Assembly (ZGHSA ZGCM-48 ZGCM-66 ZGCM-HSA)	65
Figure 23 (ZGHSA)	65
Figure 24 (ZGCM-48 ZGCM-66)	66
Figure 25 (ZGCM-HSA)	67
Install Boom Arm Assembly (ZGHSA ZGCM-48 ZGCM-66 ZGCM-HSA)	68

Zero-Gravity® Radiation Protection System Installation Guide

- Figure 26 (ZGHSA | ZGCM-HSA)68
- Figure 27 (ZGCM-48 | ZGCM-66)69
- Figure 28 (ZGCM-48 | ZGCM-66)70
- Install Carriage Cover (ZGCM-48 | ZGCM-66 | ZGCM-HSA)71
 - Figure 29 (ZGCM-HSA)71
 - Figure 30 (ZGCM-48 | ZGCM-66)71
- Install Optional Bumper (ZGCM-48 | ZGCM-66) (Figure 30)72
- Install Balancer (ZGHSA | ZGCM-48 | ZGCM-66 | ZGCM-HSA)72
 - Figure 3173
 - Figure 3273
- Install Body Shield Assembly (ZGHSA | ZGCM-48 | ZGCM-66 | ZGCM-HSA)74
 - Figure 3374
 - Figure 3475
 - Figure 3575
- Attach Shoulder Shields (ZGHSA | ZGCM-48 | ZGCM-66 | ZGCM-HSA)76
 - Figure 3676
- Balancer Installation Safety (ZGHSA | ZGCM-48 | ZGCM-66 | ZGCM-HSA)77
- Adjust Balancer (ZGHSA | ZGCM-48 | ZGCM-66 | ZGCM-HSA)78
 - Figure 3778
- Align Friction Brake & Adjust Bearing Tension (ZGHSA | ZGCM-HSA)79
 - Figure 3879
 - Figure 3980
 - Figure 4080
- Adjust Ceiling Mount Bearing & Angle Limiting Stops (ZGHSA)81
 - Figure 4181
 - Figure 4282
 - Figure 4383
- Install Support Plate Cover (ZGHSA)84
 - Figure 4484
 - Above the Unistrut Mount (Figure 44)84
 - Figure 4584
 - Below the Unistrut Mount (Figure 45)84
 - Figure 4684
- Adjust Boom Arm Length (ZGCM-66)85
 - Figure 4785
 - Figure 4886
 - Figure 4986
- Adjust Boom Arm Angle (ZGCM-48 | ZGCM-66)87
 - Figure 5087
 - Figure 5188
- Finalize Installation (ZGHSA | ZGCM-48 | ZGCM-66 | ZGCM-HSA)89
- Zero-Gravity Floor Unit Checklist**91
 - ZGM-6-5H91
- Zero-Gravity Hinged Swing Arm Checklist**92
 - ZGHSA92

Zero-Gravity Monorail Installation Checklist	93
ZGCM-48 ZGCM-66	93
Zero-Gravity Monorail Installation Checklist	94
ZGCM-HSA	94
Index of Additional System Labels	97
Body Shield Labels	97
Vest Labels	98
Limited Warranty	100
Declarations of Conformity	100
NOTES	101

Translations available on the TIDI Products website: <https://tidiproducts.com/ifu>

Oversættelser kan findes på TIDI Products' websted: <https://tidiproducts.com/ifu>

Vertalingen beschikbaar op de website van TIDI Products: <https://tidiproducts.com/ifu>

Traductions disponibles sur le site Web de TIDI Products : <https://tidiproducts.com/ifu>

Übersetzungen sind auf der Website von TIDI Products verfügbar: <https://tidiproducts.com/ifu>

Traduzioni disponibili sul sito web di TIDI Products: <https://tidiproducts.com/ifu>

Tłumaczenia są dostępne w witrynie internetowej firmy TIDI Products: <https://tidiproducts.com/ifu>

Traduções disponíveis no site dos Produtos TIDI: <https://tidiproducts.com/ifu>

Traducciones disponibles en el sitio web de TIDI Products: <https://tidiproducts.com/ifu>

Important Information

Read this Manual Before Starting to Work!

This information is necessary for the safe and efficient operation of the equipment.

This document should be stored with, or in the immediate vicinity, of the unit.

Zero-Gravity Document List

- 81000 – Preventative Maintenance Checklist
- 82000 – Uncrating Guide
- 83000 – Installation Guide
- 84000 – User's Guide

Zero-Gravity® Radiation Protection System is a registered trademark of TIDI Products, Inc.

United States Patents 7,973,299; 8,207,516; 8,558,204; 8,598,554 B2; 8,925,553; 8,933,426

For U.S. and Foreign Patent information, see [//go.tidiproducs.com/patents](http://go.tidiproducs.com/patents)

Additional Patents Pending

The contents of this publication may not be reproduced, copied, or translated in whole or in part without prior consent from TIDI Products.

Pursuant to continuous product improvement, TIDI Products reserves the right to change the equipment design and technology at any time.

All rights under the copyright laws are expressly reserved by TIDI Products.

Within the bounds of the legal requirements, the manufacturer is only responsible for the technical safety characteristics of this apparatus if the maintenance, repairs, and modifications to this apparatus are performed by TIDI Products or an approved TIDI Products representative.

The Zero-Gravity® Radiation Protection System can also be referred to as Zero-Gravity or Zero-Gravity System.

The Zero-Gravity® Radiation Protection System is available in the following options:

Floor Unit (ZGM-6-5H)

Monorail (ZGCM-48 and ZGCM-66)

Hinged Swing Arm (ZGHSA)

Monorail Hinged Swing Arm (ZGCM-HSA)

This guide applies to Zero-Gravity Systems manufactured after November 2019. For models prior to November 2019, some features may not apply. Contact TIDI Products service for additional information.

Installation Instructions

The installation instructions in this document refer to the Zero-Gravity® Radiation Protection System with the following identification:

- **Manufactured for:** TIDI Products, LLC
- **Product name:** Zero-Gravity® Radiation Protection System
- **Type designation:** Floor Unit (ZGM-6-5H), Hinged Swing Arm (ZGHSA), Monorail Hinged Swing Arm (ZGCM-HSA), Monorail 48 (ZGCM-48) or 66 inches (ZGCM-66)
- **Serial Number:** See Identification Tag (Figure 2, 3, 4, & 5)
- **Sterile covers manufactured by:** TIDI Products
- **Authorized representatives:** See Declarations of Conformity.
- **Manufacture date:** See Identification Tag (Figure 2, 3, 4, & 5)
- Conforms to Annex II, Personal Protective Equipment (EU) Regulation 2016/425 Category III, and as brought into UK law and amended.



Manufactured for:

TIDI Products, LLC
570 Enterprise Drive
Neenah, WI 54956 USA

Phone: 1.800.521.1314
+1.920.751.4300

www.tidiproducts.com

CE 2797

NOTIFIED BODY

BSI Group The Netherlands B.V.
Say Building
1066 EP Amsterdam
The Netherlands

UK
CA 0086

APPROVED BODY

BSI Assurance UK Ltd
Kitemark Court,
Davy Avenue Knowlhill,
Milton Keynes, MK5 8PP UK

Intended Use

Zero-Gravity® Radiation Protection System

See 84000 Users Guide for Intended Use

Foreseeable Misuse

Zero-Gravity® Radiation Protection System has risk and other foreseeable misuse conditions that are identified in the **Safety Symbols** section of this document. Please read this document in its entirety before using this equipment.

Safety Liability

TIDI Products assumes no liability for the safe and reliable operation of Zero-Gravity® Radiation Protection System where:

- Installation, modifications, or repairs are not performed by TIDI Products technicians or people authorized by TIDI Products.
- Authorized TIDI Products replacement parts are not used.
- Authorized TIDI Products sterility protection accessories are not used.
- The Zero-Gravity has not been installed or setup for a procedure in accordance with the steps in this document.
- The Zero-Gravity is used in a manner other than its intended use as stated above.

Safety Warning

- Repairs may only be performed by TIDI Products authorized personnel.
- The weight of body shield assembly suspended on the balancer must not be altered in any way.
- A thorough inspection of equipment should be performed, after each service call, prior to releasing the equipment for use.



WARNING!

To reduce risk of injury, installer(s) must carefully read and understand this document and be trained prior to use.

Installation Guide

This document is intended to provide guidance for the proper and safe installation of Zero-Gravity system and is used to train personnel.

- It is essential that installers read this document, in its entirety, with special consideration to keywords and symbols.
- *Particularly helpful information is italicized.*
- *Personnel removing equipment from the crate should refer to TIDI Products document 82000 (Uncrating Instructions).*
- *Installers should refer to TIDI Products document 83000 (Installation Guide).*
- *Users should refer to TIDI Products document 84000 (User's Guide).*
- *For additional information contact TIDI Products service at +1.920.751.4300.*

Pre-Installation Responsibilities

The ceiling mounting structure of a TIDI Products Zero-Gravity system should always be considered the most important detail of any project prior to installation. Zero-Gravity Hinged Swing Arm, Monorail, and Monorail Hinged Swing Arm systems depends on properly designed and installed mounting structures to deliver years of performance. **Generally, structural supports in the ceiling must be installed by the owner or owner designated contractor. All fixed attachments between Zero-Gravity system and building superstructures must be approved by the facilities engineer of record.** TIDI Products or their authorized representatives will complete the installation following the approval of all required pre-installation activities by the customer. See the Zero-Gravity Ceiling Pre-Installation Guide (TIDI Products document 32398) for additional details.



WARNING!

The Zero-Gravity ceiling mounting structure must be customer approved prior to installing Zero-Gravity system. Failure to have properly designed support structure could cause structural failure of the ceiling support system and could result in serious risk of injury or death to patient or operator and or damage to equipment or property.

System Description

Zero-Gravity Floor Unit (ZGM-6-5H)

Features: Mobile unit with heavy base with casters and locks, variable-height mast, 48" pivoting boom.



Zero-Gravity Hinged Swing Arm Unit (ZGHSA)

Features: Ceiling mounted central pivot-plate, swinging rigid arm, 48" lower track.



Zero-Gravity Monorail Hinged Swing Arm (ZGCM-HSA)

Features: Ceiling mounted upper track, central pivot on upper trolley with 48" lower track.

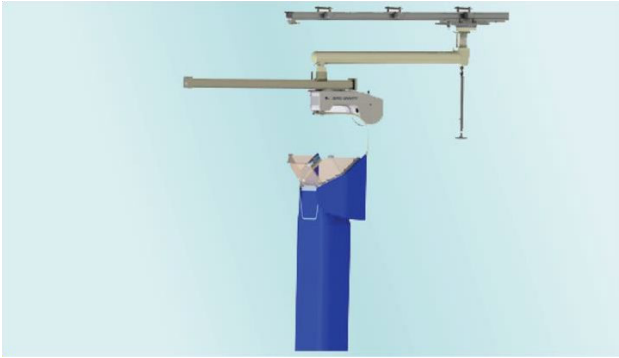



Zero-Gravity Monorail Unit (ZGCM-48 or ZGCM-66)

Features: Ceiling mounted upper track, (ZGCM-48) 48" lower track or (ZGCM-66) 66" lower track.









Safety Symbols





Important information in this document is marked with symbols and keywords. Keywords such as **WARNING**, **CAUTION**, or **ATTENTION** indicate the level of risk involved. The symbols emphasize the message visually.









	<p>WARNING! Indicates a potentially hazardous situation, which could result in a serious risk of injury or death to patient or operator and or damage to equipment or property.</p>
	<p>CAUTION! Indicates a potentially hazardous situation, which could result in a minor or moderate risk of injury to patient or operator and or damage to equipment or property.</p>
<p>ATTENTION!</p>	<p>(Without safety alert symbol) Indicates a situation that may result in damage to equipment or property.</p>
	<p>NOTE <i>Useful additional information and tips.</i></p>



Document Safety Symbols

Read and follow all safety instructions in the document and on the device.

	<p>WARNING! To reduce risk of injury, installer(s) must carefully read and understand this document and be trained prior to use.</p>
	<p>WARNING! The Zero-Gravity ceiling mounting structure must be customer approved prior to installing Zero-Gravity system. Failure to have properly designed support structure could cause structural failure of the ceiling support system and could result in serious risk of injury or death to patient or operator and or damage to equipment or property.</p>
	<p>WARNING! The system must be assembled and installed by TIDI Products authorized representatives. TIDI Products recommends using a minimum of two persons capable of lifting 100 pounds (45 kilograms) to install the system.</p>
	<p>WARNING! TIP OVER HAZARD Disassemble device prior to transport. Lower assembly to lowest height, remove body shield, remove balancer and remove boom arm.</p>
	<p>WARNING! TIP OVER HAZARD To relocate device in surgical suite: raise leveling feet; roll over flat surfaces with no obstructions.</p>
	<p>WARNING! INJURY RISK Balancer is mounted to a wheeled Trolley and is free to roll. During assembly, Boom Arm End Stop Cap is removed and Balancer can easily roll and fall out of Boom Arm. Do not leave Balancer unattended while End Stop Cap is removed.</p>
	<p>WARNING! INJURY RISK-CABLE HAZARD Annual inspections must be performed on the cable. Cables must be replaced if there are signs of wear.</p>
	<p>WARNING! INJURY RISK-CABLE HAZARD Excessive rotation of Body Shield may cause Balancer Cable to break. The Body Shield must be lowered and allowed to unwind after each use, in an unlocked position. Annual inspections must be performed on the cable. Cables must be replaced if there are signs of wear.</p>

	<p>WARNING! INJURY RISK When extending cable from balancer (with body shield not attached), personnel must maintain control of the spring-loaded cable at all times. Failure to maintain control of cable under spring tension can cause serious injury or property damage.</p>
	<p>WARNING! INJURY RISK-BALANCER CABLE Unlocking balancer lock screw without body shield attached can cause severe injury. If the body shield is not attached, the Zero-Gravity balancer cable may rapidly retract in an uncontrolled manner.</p>
	<p>WARNING! RADIATION HAZARD The Body Shield must be handled with care to avoid damage to the Body Shield protective lead material. If the Body Shield is damaged, it must be inspected according to the Body and Face Shield Fluoroscopy Inspection section of the User's Guide (TIDI Products document 84000).</p>
	<p>WARNING! INJURY RISK-HEAVY EQUIPMENT Use care when handling the Hinged Swing Arm Assembly. The Support Plate Assembly weighs approximately 200 pounds (90 kilograms) and must be handled using a mechanical lift.</p>
	<p>WARNING! INJURY RISK-HEAVY EQUIPMENT Use care when handling the Rail Assembly. The Rail Assembly weighs ~ 150 pounds (68 kilograms) and must be handled by two or more people.</p>
	<p>WARNING! INJURY RISK-HEAVY EQUIPMENT Use care when handling the Drop Tube. The Drop tube weighs approximately 140 pounds (64 kilograms). Two or more people are required for handling.</p>
	<p>WARNING! COLLISION RISK Leaving Lock Pin in disengaged (unlocked ) position, while operating Boom Arm, may lead to collisions with other devices in operating room.</p>
	<p>CAUTION! INJURY RISK Failure to maintain control of column, when raising or lowering, can result in personal injury or property damage.</p>
	<p>CAUTION! INJURY RISK Do not attempt to relocate Floor Unit during a procedure. Incorrect system positioning or adjustment may cause personal injury or equipment damage.</p>

	<p>CAUTION! INJURY RISK Zero-Gravity floor unit is heavy. Use caution when handling the device.</p>
	<p>Do not release balancer cable unless the clamp stop is securely fastened and tightened to the body shield frame.</p>
	<p>CAUTION! EQUIPMENT DAMAGE RISK Do not remove Rail End Stops, allowing the Carriages to accidentally slide off the Rail. Ball bearings may be lost if the Carriages are removed.</p>
	<p>CAUTION: Heavy Equipment Use care when handling the Boom Arm assembly. The Boom Arm assembly weighs ~ 40 pounds (18 kilograms) for the ZGM-6-5H, ZGHSA, ZGCM-HSA and ZGCM-48, and the ZGCM-66 weighs ~ 50 pounds (23 kilograms). Two people are required for handling.</p>
	<p>CAUTION! EQUIPMENT DAMAGE RISK Attempting to adjust the Balancer assembly while the cable locking screw is locked will cause permanent internal damage to the Balancer and inability to balance the Body Shield.</p>
	<p>CAUTION! EQUIPMENT DAMAGE RISK The 66-inch-long Boom has stop screws to limit positioning. Travel is limited to avoid unsafe loading on the Boom. Do not remove the travel limiting screws (ZGCM-66 only).</p>
	<p>CAUTION! EQUIPMENT DAMAGE RISK Do not remove and discard protective foam cover on Face Shield until in-service training.</p>
	<p>CAUTION! PINCH POINT HAZARD Never push or pull Zero-Gravity floor unit by placing hands on large D-shape plate. Casters may swivel and pinch hands or fingers. Always use push handles to move Zero-Gravity system.</p>
	<p>CAUTION! PINCH POINT HAZARD Use care when moving the Carriage along the Rail Assembly. Fingers or hands can be pinched between the moving Carriage and the Rail End Stops.</p>

	<p>CAUTION! PINCH POINT HAZARD Use care when moving the Balancer along the Boom with the Trolley. Fingers or hands can be pinched between the moving Trolley and the End Stops.</p>
	<p>CAUTION! PINCH POINT HAZARD Use care when sliding the Boom under the Swivel Center. Fingers or hands can be pinched between the Swivel and stop screws or the End Stop Cap in the top of the Boom.</p>
	<p>WARNING! HANDLING PEOPLE HAZARD Handling people with this equipment can cause severe injury. Do not use for lifting, lowering or transporting people.</p>
<p>ATTENTION!</p>	<p>Ensure shoulder bolts are tightened securely.</p>
<p>ATTENTION!</p>	<p>Ensure Body Shield assembly is tightly secured in Balancer Connector and Body Shield is hanging vertically (not tilted).</p>
<p>ATTENTION!</p>	<p>Installation checklists are required as proof of system operational validation prior to clinical use.</p>
<p>ATTENTION!</p>	<p>Pay strict attention to orientation of the Boom Arm Assembly in relation to the surgical table. Orientation arrows MUST be aligned and Table arrows MUST be pointing to the surgical table. Zero-Gravity will not function properly if mounted in the wrong orientation.</p>
<p>GENERAL</p>	<p>Personnel working with Zero-Gravity system(s) must be properly trained. Repairs or maintenance may only be performed by TIDI Products representatives or representatives authorized by TIDI Products.</p>

Device Safety Symbols

Important information on the device is marked with symbols and keywords.

	<p>WARNING! TIP OVER HAZARD Do not lean or hang on boom.</p>
<p>⚠ WARNING</p> <p>MAGNETIC FIELD!</p> 	<p>WARNING! MAGNETIC FIELD HAZARD: CARDIAC DEVICE RISK: The Zero-Gravity body shield is magnetically coupled to the Zero-Gravity vest and may cause a hazard with user defibrillators or pacemakers.</p>
<p>⚠ WARNING</p> <p>RADIATION EXPOSURE!</p> <p>ALWAYS:</p> <ul style="list-style-type: none"> • Set the height of face shield at temple height • Use vest to couple with body shield • Lower Shoulder Shields into position <p>DO NOT EXPOSE UNPROTECTED BACK TO RADIATION SOURCE!</p> 	<p>WARNING! RADIATION EXPOSURE Failure to set body shield at the proper height, failure to use a vest, failure to couple vest to body shield, or failure to lower shoulder shields into position may cause excess body, cranium or lens radiation exposure. NEVER expose unprotected back to radiation source!</p>
	<p>CAUTION! PINCH POINT Always keep hands and feet clear of device during operation. Failure to keep hands and feet clear could result in serious injury.</p>
	<p>ATTENTION! TRIP HAZARD Low light reflective tape strips located on base help users see and avoid a trip hazard.</p>
 <p>WATCH YOUR HEAD</p>	<p>CAUTION! COLLISION RISK Retract Handle to highest position when not in use to avoid damage to equipment and personnel.</p>



READ INSTRUCTIONS FOR USE

To reduce risk of injury, user(s) must carefully read and understand this document and be trained prior to use.



CAUTION! RADIATION RISK

To reduce risk of injury, user(s) must exercise caution to avoid contamination with or undue exposure to ionizing radiation.

Device Operation Symbols

Important information on the device is marked with symbols and keywords.

	<p>Locking Pin is used in adjusting vertical column height. If Pin is disengaged vertical column height is adjustable. If Pin is engaged vertical column height is fixed.</p>
	<p>Vertical Column Snubber Handle is used in adjusting vertical column height. Vertical column height is fixed when Handle is locked. Vertical column height is adjustable when Handle is unlocked.</p>
	<p>Bearing Rotational Lock is used to stop the boom arm from swinging. If the Boom Lock is fastened, the Boom Arm is fixed to the vertical column. If the Boom Lock is unfastened, the boom is free to rotate.</p>
	<p>Caster Wheel Lock is used to fix the position of the base on the floor. If the casters are locked, they will not roll or swivel. If the casters are unlocked, they will roll and swivel.</p>
	<p>Leveling Feet are used to level the unit for use and help fix it to one location on the floor. Lower the leveling feet to the ground to fix the unit to one location on the floor. Raise the leveling feet to move the unit. Fine adjustments to level the base are also made using the leveling feet.</p>
	<p>Boom Arm Adjustment Knob allows Boom adjustment relative to the Swivel Center. If locked the Boom length cannot be adjusted. If unlocked, the Boom length can be adjusted.</p>
	<p>The Pull Pin Handle allows rotational Boom adjustment. If locked, the Boom will not rotate. If unlocked, the Boom will rotate.</p>

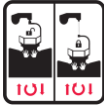

Overhead “Twist and Lock” is used to store or secure the body shield during storage or sterile draping. If locked, the Body Shield is in a fixed position. If unlocked, the Body Shield is free to move.

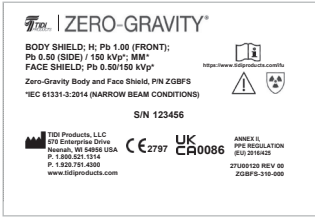

Body Shield System Label is used to define the Body Shield:

- H designates a heavy protective apron per IEC 61331-3:2014, Section 5.2
- MM designates an apron sized per IEC 61331-3:2014, Section 5.2 with
 - A=50.0 inches (127.0 centimeters)
 - B=23.6 inches (60.0 centimeters)
 - C=37.4 inches (95.0 centimeters)
- Front (1.0), side (0.5), and face shield (0.5) radiation protection in millimeters of lead equivalent per 150 kVp (Narrow Beam Conditions)
- Standards followed
- Contact information



Shield height label is used to set magnet to proper body shield height to connect with vest.



+/- Balancer label shows tightening and loosening directions for adjusting balancer.



Column height label is used to set preferred boom height.

Body Shield Overview



See **Figure 1** below and the chart on the next page for dimensions to define the protection area for body shield users.

Figure 1

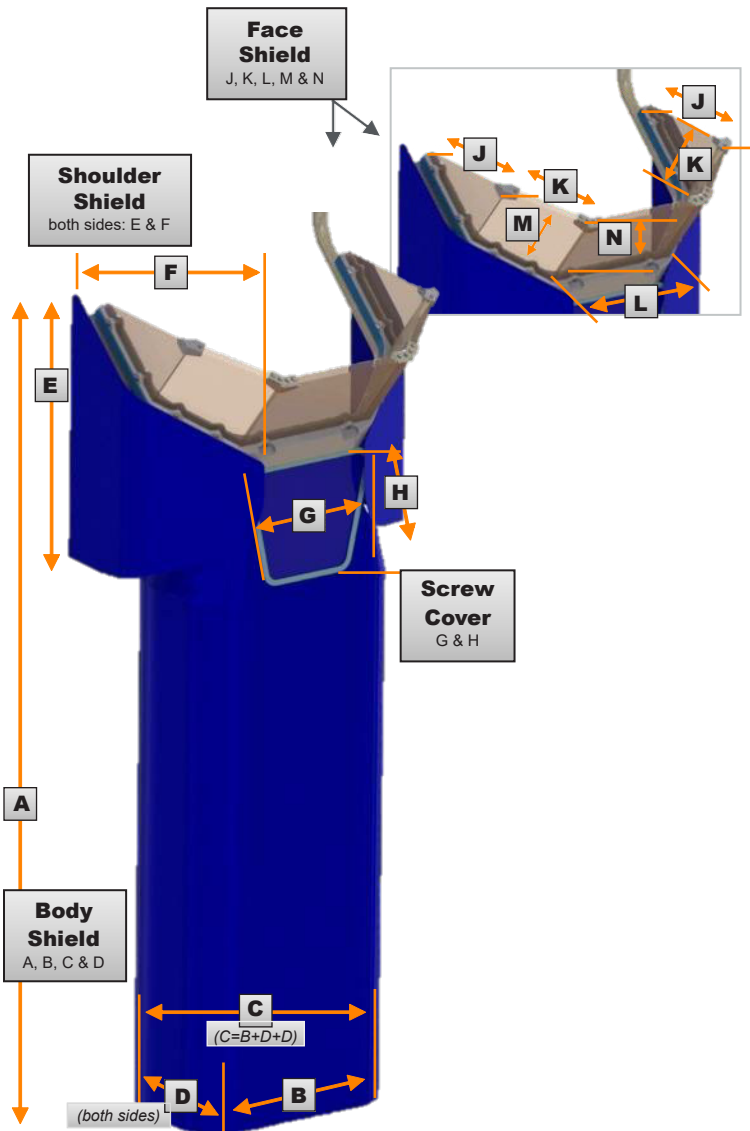

Figure 1 Chart

* IEC 61331-3-Section 5.3, a standard that defines sizing for wrap around radiation aprons is not applicable to the Body Shield. Zero-Gravity meets or exceeds the cited requirements. See Figure 1 and the chart below.

Dimension	Item	Inch	Centimeter	Lead Thickness Equivalent (millimeters)	IEC 61331-3 Section 5.3 Size
A*	Body Shield	50.0	127.0	1.0 or 0.5/150 Peak kilovoltage	MM
B*	Body Shield	23.6	60.0	1.0/150 Peak kilovoltage	Medium B
C*	Body Shield	37.4	95.0	1.0 or 0.5/150 Peak kilovoltage	N/A
D	Body Shield	6.9	17.5	0.5/150 Peak kilovoltage	N/A
E (Both Sides)	Shoulder Shield	17.7	45.0	1.0/150 Peak kilovoltage	N/A
F (Both Sides)	Shoulder Shield	15.0	38.0	1.0/150 Peak kilovoltage	N/A
G	Screw Cover	9.0	23.0	1.0/150 Peak kilovoltage	N/A
H	Screw Cover	7.9	20.0	1.0/150 Peak kilovoltage	N/A
J	Face Shield	7.0	18.0	0.5/150 Peak kilovoltage	N/A
K		6.3	16.0		
L		9.8	25.0		
M		6.3	16.0		
N		6.9	17.5		

System Overview

Figure 2 (ZGM-6-5H)

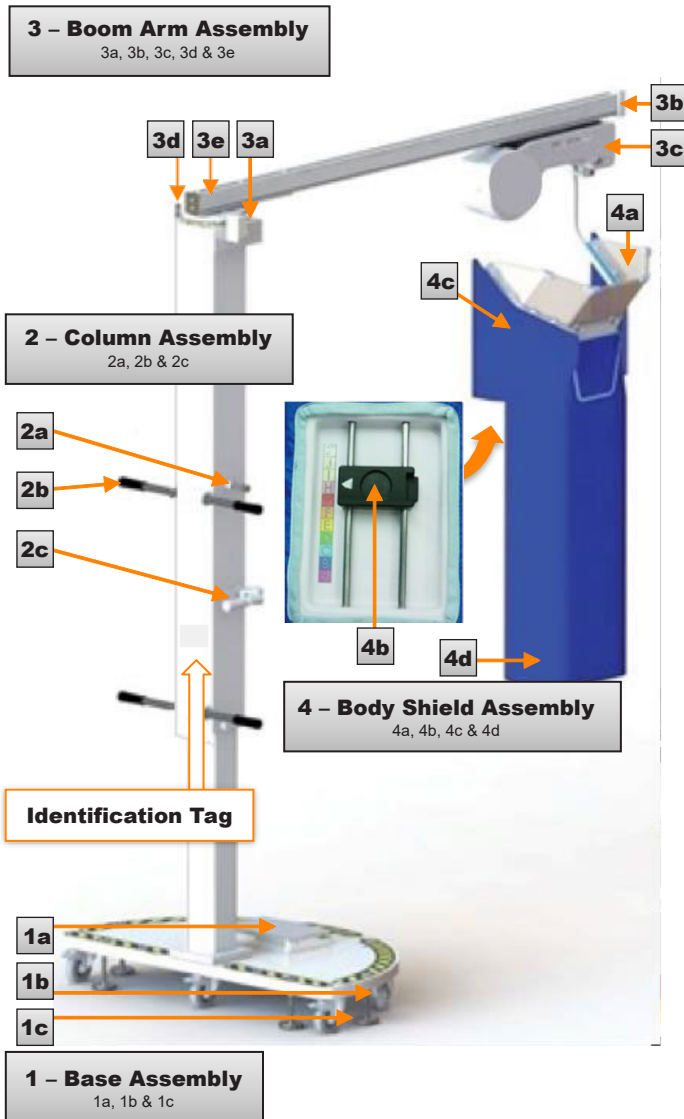

Figure 2 Chart (ZGM-6-5H)

Item	Part	Purpose and Specification
1	Base Assembly	Supports column assembly (2) and boom arm assembly (3). Weight: 660 pounds (300 kilograms) Width: 48 inches (122 centimeters) Depth: 28 inches (71 centimeters)
1a	Toolbox	Contains: (1) each 5/16 inch, 5/32 inch and 1/8 inch hex wrenches; (1) flat blade screw driver; (1) 3/8 inch square drive ratchet wrench; (1) 3/8 inch square drive 17 millimeter deep well socket; (1) 3/8 inch square drive 3/8 inch hex bit socket; (1) 3/8 inch square drive with 3 inch extension; (1) adjustable wrench, (1) Leveling Eye
1b	Locking Casters	If necessary, allows system to be repositioned within suite or moved to another suite.
1c	Leveling Feet	Used to stabilize and level system
2	Column Assembly	Telescoping, vertical column which locks into user-preferred heights (includes Identification Tag).
2a	Locking Pin	Spring loaded pull pin adjusts column assembly (2) height
2b	Lift Handles	Used to steer base (1) into position during relocation. Also used for raising column assembly (2) and boom arm assembly (3) into procedure position.
2c	Snubber Handle	Secures column assembly (2) into place in conjunction with the locking pin.
3	Boom Arm Assembly	Carries body shield (4d) and related parts. Length: 77 inches (196 centimeters)
3a	Turntable Bearing	Permits 150° rotation of boom arm assembly (3).
3b	End Stop Cap	Ensures balancer (3c) remains on boom arm assembly (3)
3c	Balancer	Supports body shield assembly (4)
3d	Bearing Rotational Lock	Used to stop the boom arm (3) from swinging.
3e	Docking Station	Using a magnet, prevents unwanted sliding of the Body Shield (4) when it is not in use

Figure 2 Chart (ZGM-6-5H)

Item	Part	Purpose and Specification
4	Body Shield Assembly (ZGBFS)	Consists of face shield (4a), Connector (4b), Right and Left shoulder flaps (4c), and body shield (4d). Total weight: ~ 54 pounds (24.5 kilograms)
4a	Face Shield	0.50-millimeter Pb Equivalent/150 Peak kilovoltage [^] . Eye shield UV scale Number 2-1.2/2C-1.2, Optical Class 1, Increased Robustness S.
4b	Connector	Secures body shield assembly (4) to user's vest, adjusts to 11 positions: 0.5 inch (1.3 centimeters) per position – 5 inches (13 centimeters) vertical range
4c	Shoulder Shields, Right (ZGSS-R) and Left (ZGSS-L)	1.00-millimeter Pb Equivalent/150 Peak kilovoltage [^]
4d	Body Shield	1.00-millimeter Pb Equivalent/150 Peak kilovoltage [^] on Front: .50-millimeter Pb Equivalent/150 Peak kilovoltage [^] on sides
Not shown	Vest	Worn by user to ensure proper alignment of body shield assembly (4), ensuring optimum protection of user. Sizes: Extra-Small (ZGAV-XS), Small (ZGAV-S), Medium (ZGAV-M), Large (ZGAV-L), Extra-Large (ZGAV-XL), Triple Extra-Large (ZGAV3XL)
Not shown	Sterile Cover (ZGD20WA-LOOP)	Polyethylene; used on body shield (4d) to maintain sterility.

Figure 2 – Other Considerations (ZGM-6-5H)

Other Considerations	Description
Base push force, starting resistance	Approximate Force: 31 pounds (138 Newtons)
Base push force, rolling resistance	Approximate Force: 21 pounds (94 Newtons)
System height, maximum in use ("F" position)	108 inches (274 centimeters) when column (2) is fully extended
System height, minimum in use ("A" position)	94 inches (239 centimeters) when column (2) and boom arm assembly (3) attached
Transport height, minimum	78 inches (198 centimeters) when column (2) is fully retracted and boom arm assembly (3) is removed
Operational load, maximum (boom load)	70 pounds (32 kilograms)
User Stature	4 feet 10 inches (147 centimeters) to 6 feet 5 inches (196 centimeters)
Required Expertise	Educated in the use of radiology safety equipment, knowledge of and ability to maintain surgical sterility procedures, knowledge and understanding of risks involved in using radiology equipment, understands hygiene and sterility principles, experience in use of radiology equipment in a human operative environment.
Assembled weight	750 pounds (341 kilograms)

Use Safety Confirm that system has been installed per the TIDI Products issued *Installation Guide*



CAUTION! INJURY RISK

Failure to maintain control of column, when raising or lowering, can result in personal injury or property damage.



CAUTION! INJURY RISK

Do not attempt to relocate Floor Unit during a procedure. Incorrect system positioning or adjustment may cause personal injury or equipment damage.

Figure 3 (ZGHSA)

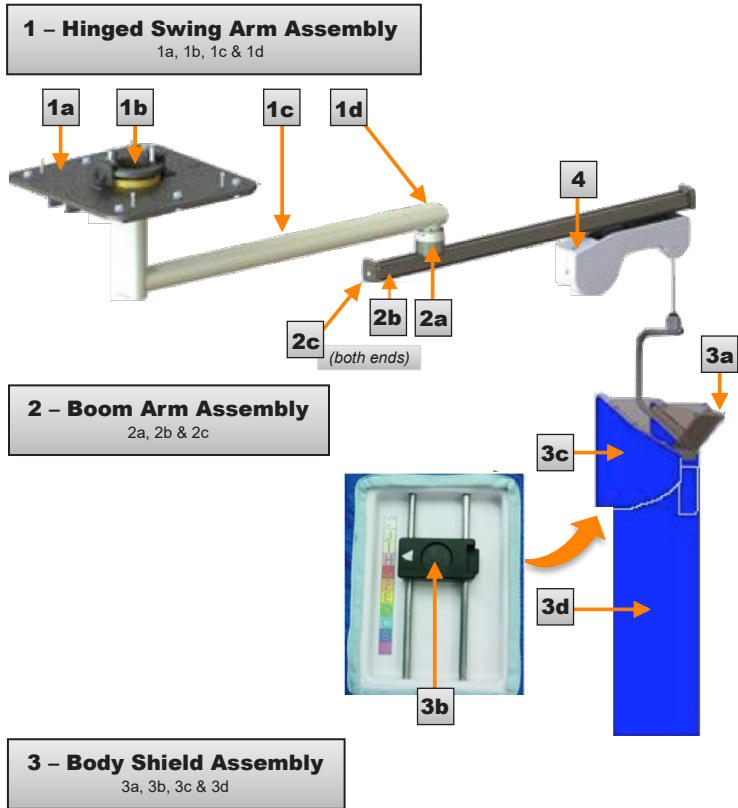

Figure 3 Chart (ZGHSA)

Item	Part	Purpose and Specification
1	Hinged Swing Arm Assembly	Supports the boom arm assembly (2). Total weight: ~ 340 pounds (154 kilograms)
1a	Support Plate Assembly	Provides rigid support and fastens unit to the ceiling. Total weight: ~ 200 pounds (90 kilograms)
1b	Ceiling Swivel	Allows unit to rotate 360 degrees around procedure room
1c	Drop Tube	Connects the Boom Arm Assembly (2) to ceiling swivel (1b) Total weight: ~ 140 pounds (64 kilograms)
1d	Identification Tag	Provides identifying information for the unit.
2	Boom Arm Assembly	Carries body shield and related parts. Boom Arm is 65 inches (165 centimeters) long with a total weight of 40 pounds (18 kilograms)
2a	Swivel Support	Mounted to Drop Tube (1c), supports Boom Arm Assembly (2)
2b	Docking Station	Using a magnet, prevents unwanted sliding of the Body Shield (3) when it is not in use
2c	End Stop Cap	Ensures balancer (4) remains on boom arm assembly (2).
3	Body Shield Assembly (ZGBFS)	Consists of Face Shield (3a), Connector (3b), and Body Shield (3d). Total weight ~ 54 pounds (24.5 kilograms).
3a	Face shield	0.50-millimeter Pb Equivalent / 150 kVp [^] . Eye shield UV scale Number 2-1.2/2C-1.2, Optical Class 1, Increased Robustness S.
3b	Connector	Secures Body Shield Assembly (3) to user Vest, adjusts to 11 positions: 0.5 inch (1.3 centimeters) per position – 5 inches (13 centimeters) vertical range
3c	Shoulder Shields, Right (ZGSS-R) and Left (ZGSS-L)	1.00-millimeter Pb / 150 kVp [^]
3d	Body shield	1.00-millimeter Pb / 150 kVp [^] on front 0.50-millimeter Pb Equivalent / 150 kVp [^] on sides
4	Balancer	Supports leaded Body Shield Assembly (3).

[^]Narrow Beam Conditions

Figure 3 Chart (ZGHSA)

Item	Part	Purpose and Specification
Not shown	User Tool Kit	<ul style="list-style-type: none"> • 17-millimeter-deep well socket, 3/8-inch square drive • 3-inch extension with 3/8-inch square drive • 5/32-inch ball end hex key wrench • 7 1/2-inch ratchet (3/8-inch drive)
Not shown	Vest	<p>Worn by user to ensure proper alignment of Body Shield assembly (3), ensuring optimum protection of user. Sizes:</p> <p>Extra-Small (ZGAV-XS) Small (ZGAV-S), Medium (ZGAV-M), Large (ZGAV-L), Extra-Large (ZGAV-XL), Triple Extra-Large (ZGAV-3XL)</p>
Not shown	Sterile cover (ZGD20WA-LOOP)	Polyethylene; used on body shield to maintain sterility.
Not shown	System Components/ Unistrut Fastener Assembly	Hex Screw, Lock Washer, Flat Washer, Channel Nut

Figure 3 – Other Considerations (ZGHSA)

Other Considerations	Description
Required Ceiling Height	107 inches (272 centimeters) minimum
Balancer Working Length	46.5 inches (118 centimeters)
Assembled Weight	~ 500 pounds (227 kilograms)
Boom Arm Rotation	360°
Drop Tube Rotation	360°; or angle limiting with cushioned stops
Operational load, maximum (boom load)	~ 74 pounds (34 kilograms)
User Stature	4 feet 10 inches (147 centimeters) to 6 feet 5 inches (196 centimeters)
Required Expertise	Educated in the use of radiology safety equipment, knowledge of and ability to maintain surgical sterility procedures, knowledge and understanding of risks involved in using radiology equipment, understands hygiene and sterility principles, experience in use of radiology equipment in a human operative environment.

Figure 4 (ZGCM-48 | ZGCM-66)

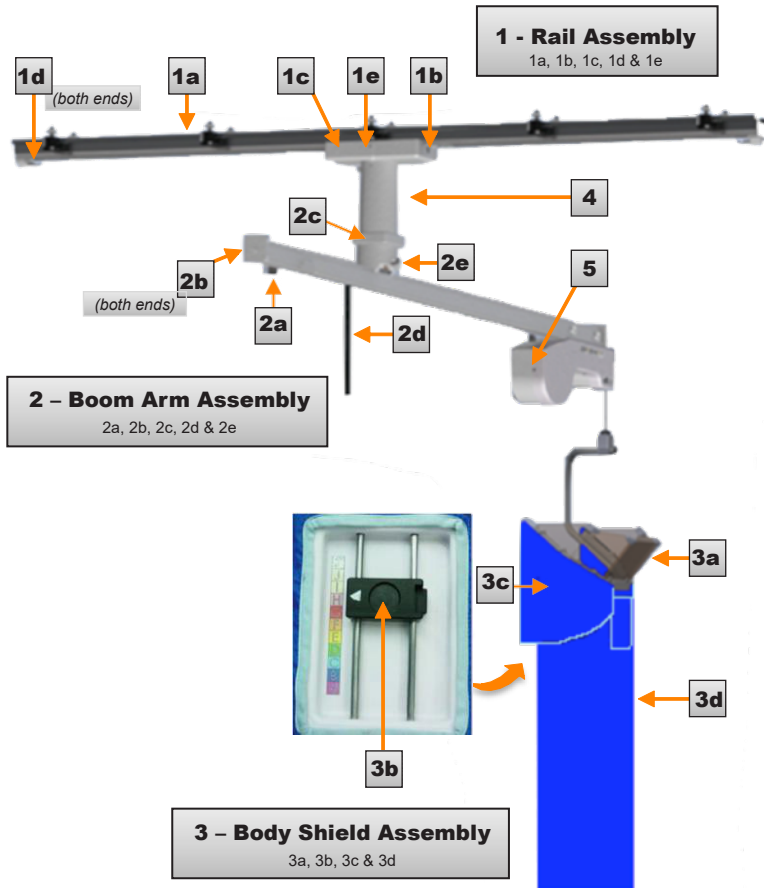

Figure 4 Chart (ZGCM-48 | ZGCM-66)

Item	Part	Purpose and Specification
1	Rail Assembly	Supports the Drop Tube (4). Total weight: 150 pounds (68.0 kilograms)
1a	Rail	Ceiling mounted, supports Carriage, Width: 5 inches (12.7 centimeters) Length: 118 inches (3 meters).
1b	Carriage	Provides mounting surface for Drop Tube (4) and travels up and down the Rail (1a).
1c	Carriage Covers	Protect Carriage (1b).
1d	End Stop	Provides a positive stop for the Carriage (1b).
1e	Identification Tag	Provides identifying information for the unit.
2	Boom Arm Assembly	Carries Body Shield and related parts <ul style="list-style-type: none"> • ZGCM-48 is 65 inches (165 centimeters) long with a total weight: 40 pounds (18 kilograms). • ZGCM-66 is 107 inches (272 centimeters) long with a total weight of 50 pounds (23 kilograms).
2a	Docking Station	Using a magnet, prevents unwanted sliding of the Body Shield (3) when it is not in use
2b	End Stop Cap	Ensures Balancer (5) remains on Boom Arm assembly (2).
2c	Swivel Assembly	Permits 360° rotation of boom arm assembly (2).
2d	Lock Pin	Allows the Boom Arm assembly (2) to lock to one of (6) preset positions. Actuation is with a pull pin handle.
2e	Boom Arm Adjustment Knob	Clamps and unclamps to allow the Boom Arm to adjust the length of the Boom under the Swivel Center.
3	Body Shield Assembly (ZGBFS)	Consists of Face Shield (3a), Body Shield (3d), and Connector (3b). Total weight ~ 54 pounds (24.5 kilograms).
3a	Face shield	0.50-millimeter Pb Equivalent / 150 kVp [^] . Eye shield UV scale Number 2-1.2/2C-1.2, Optical Class 1, Increased Robustness S.
3b	Connector	Secures Body Shield assembly (3) to user Vest, adjusts to 11 positions: 0.5 inch (1.3 centimeters) per position – 5 inches (13 centimeters) vertical range
3c	Shoulder shields Right (ZGSS-R) and Left (ZGSS-L)	1.00-millimeter Pb / 150 kVp [^]

3d	Body Shield	1.00-millimeter Pb / 150 kVp [^] on front 0.50-millimeter Pb Equivalent / 150 kVp [^] on sides
4	Drop Tube	Mounted to the Carriage (1b), supports Boom Arm assembly (2).
5	Balancer	Supports leaded Body Shield assembly (3).

[^]Narrow Beam Conditions

Figure 4 Chart (ZGCM-48 | ZGCM-66)

Item	Part	Purpose and Specification
Not Shown	User Tool Kit	<ul style="list-style-type: none"> • 17-millimeter-deep well socket, 12 point with 3/8-inch square drive • 3-inch extension with 3/8-inch square drive • 5/32-inch ball end hex key wrench • 7 1/2-inch ratchet (3/8-inch drive)
Not shown	Vest	<p>Worn by user to ensure proper alignment of Body Shield assembly (3), ensuring optimum protection of user. Sizes:</p> <p>Extra-Small (ZGAV-XS), Small (ZGAV-S), Medium (ZGAV-M), Large (ZGAV-L), Extra-Large (ZGAV-XL), Triple Extra-Large (ZGAV-3XL)</p>
Not shown	Sterile cover (ZGD20WA-LOOP)	Polyethylene; used on Body Shield (3) to maintain sterility.
Not shown	Kitted Items	<ul style="list-style-type: none"> • (12) M8 X 20-millimeter-long Grade 8 Socket Head Cap Screws • (8) M8 X 30-millimeter-long Grade 8 Socket Head Cap Screws • Carriage Covers • (10) Toe Clamp Assemblies • (1) Neoprene Bumper with 10-32 stainless steel hex jam nut • (6) 10-32 x 1/2-inch-long stainless steel Phillips panhead screws

Figure 4 – Other Considerations (ZGCM-48 | ZGCM-66)

Other Considerations	Description
Required Ceiling Height	102 inches (259 centimeters) minimum
Balancer Working Length for ZGCM-48	46.5 inches (118 centimeters)
Balancer Working Length for ZGCM-66	89.0 inches (226 centimeters)
Carriage Working Length (between End Stops)	96.0 inches (244 centimeters)
Assembled weight ZGCM-48	~ 315 pounds (143 kilograms)
Assembled weight ZGCM-66	~ 325 pounds (147 kilograms)
Boom Arm Rotation	360°; or angle limiting with lock pin option in 6 positions.
Operational load, maximum (boom load)	~ 74 pounds (34 kilograms)
User Stature	4 feet 10 inches (147 centimeters) to 6 feet 5 inches (196 centimeters)
Required Expertise	Educated in the use of radiology safety equipment, knowledge of and ability to maintain surgical sterility procedures, knowledge and understanding of risks involved in using radiology equipment, understands hygiene and sterility principles, experience in use of radiology equipment in a human operative environment.

Figure 5 (ZGCM-HSA)

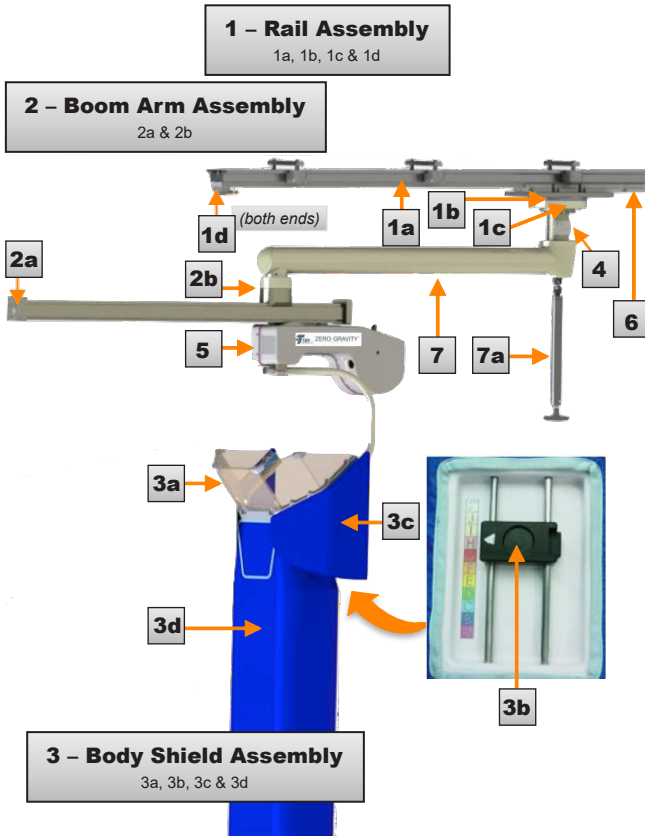

Figure 5 Chart (ZGCM-HSA)

Item	Part	Purpose and Specification
1	Rail Assembly	Supports the Drop Tube (4). Total weight: 150 pounds (68.0 kilograms)
1a	Rail	Ceiling mounted, supports Carriage, Width: 5 inches (12.7 centimeters) Length: 118 inches (3 meters).
1b	Carriage	Provides mounting surface for Drop Tube (4) and travels up and down the Rail (1a).
1c	Carriage Covers	Protect Carriage (1b).
1d	End Stop	Provides a positive stop for the Carriage (1b).
2	Boom Arm Assembly	Carries Body Shield and related parts. Length: 59 inches (150 centimeters). Total weight ~ 40 pounds (18 kilograms).
2a	End Stop Cap	Ensures Balancer (5) remains on Boom assembly (2).
2b	Swivel Support	Mounted to Swivel Boom Assembly (7), permits 360° rotation of Boom Arm Assembly (2).
3	Body Shield Assembly (ZGBFS)	Consists of Face Shield (3a), Body Shield (3d), and Connector (3b). Total weight ~ 54 pounds (24.5 kilograms).
3a	Face shield	0.50-millimeter Pb Equivalent / 150 kVp [^] . Eye shield UV scale Number 2-1.2/2C-1.2, Optical Class 1, Increased Robustness S.
3b	Connector	Secures Body Shield assembly (3) to user Vest, adjusts to 11 positions: 0.5 inch (1.3 centimeters) per position – 5 inches (13 centimeters) vertical range
3c	Shoulder shields, Right (ZGSS-R) and Left (ZGSS-L)	1.00-millimeter Pb / 150 kVp [^]
3d	Body Shield	1.00-millimeter Pb / 150 kVp [^] on front 0.50-millimeter Pb Equivalent / 150 kVp [^] on sides
4	Drop Tube	Mounted to the Carriages (1b), supports Swivel Assembly (7).
5	Balancer	Supports leaded Body Shield assembly (3).
6	Identification Tag	Provides identifying information for the unit.
7	Swivel Boom Assembly	Mounted to Drop Tube (4). Provides a double swivel connection to support Boom Arm Assembly (2).
7a	Handle	Used to push or pull carriage (1b) on the Rail Assembly (1).

[^]Narrow Beam Conditions

Figure 5 Chart (ZGCM-HSA)

Item	Part	Purpose and Specification
Not Shown	User Tool Kit	<ul style="list-style-type: none"> • 17-millimeter-deep well socket, 12 point with 3/8-inch square drive • 3-inch extension with 3/8-inch square drive • 5/32-inch ball end hex key wrench • 7 1/2-inch ratchet with speed ring (3/8-inch drive)
Not Shown	Vest	<p>Worn by user to ensure proper alignment of Body Shield assembly (3), ensuring optimum protection of user. Sizes:</p> <p>Extra-Small (ZGAV-XS), Small (ZGAV-S), Medium (ZGAV-M), Large (ZGAV-L), Extra-Large (ZGAV-XL), Triple Extra-Large (ZGAV-3XL)</p>
See Figure 10	Docking Station	<p>Using a magnet, prevents unwanted sliding of the Body Shield (3) when it is not in use.</p>
Not Shown	Sterile cover (ZGD20WA-LOOP)	<p>Polyethylene; used on Body Shield (3) to maintain sterility.</p>
Not Shown	Kitted Items	<ul style="list-style-type: none"> • (12) M8 X 30 millimeters long Blue Alloy Socket Head Cap Screws, Grade 12.9 • (8) 5/16-18 X 1-inch-long Grade 8 Socket Head Cap Screws • Carriage Cover (2 pieces) • (10) Clamp Assemblies with covers • (5) Unistrut Support Plates • (1) Brake Shoe • (4) 10-32 X 1/2-inch-long stainless steel Phillips panhead screws • (3) 3/8-16 X 1/2-inch Set Screws with Jam Nuts

Figure 5 – Other Considerations (ZGCM-HSA)

Other Considerations	Description
Required Ceiling Height	108 inches (274 centimeters) minimum
Balancer Working Length for ZGCM-HSA	46.5 inches (118 centimeters)
Carriage Working Length (between End Stops)	96.0 inches (244 centimeters)
Assembled weight ZGCM-HSA	~ 370 pounds (168 kilograms)
Boom Arm Rotation	360°
Operational load, maximum (boom load)	~ 74 pounds (34 kilograms)
User Stature	4 feet 10 inches (147 centimeters) to 6 feet 5 inches (196 centimeters)
Required Expertise	Educated in the use of radiology safety equipment, knowledge of and ability to maintain surgical sterility procedures, knowledge and understanding of risks involved in using radiology equipment, understands hygiene and sterility principles, experience in use of radiology equipment in a human operative environment.

Installation Tools



The system must be assembled and installed by TIDI Products authorized representatives.

TIDI Products recommends using a minimum of two persons capable of lifting 100 pounds (45 kilograms) to install the system.



Use of fasteners other than those recommended by TIDI products should be approved by facility engineer of record and recorded.

Suggested Installation Tools (ZGM-6-5H)

Necessary tools are supplied in the toolbox located in the base of the Floor Unit.

Required Installation Tools – Ceiling Mounted Unit (ZGHSA | ZGCM-HSA | ZGCM-48 | ZGCM-66)

1. Inclinator (digital level)
2. Tape Measure ~ 25 feet (8 meters) long
3. Ball end hex wrench set (metric and imperial)
4. 17-millimeter-deep well socket, 12 point with 3/8-inch drive
5. 3-inch extension with 3/8-inch drive
6. Phillips and flat blade screw drivers
7. Torque wrench – 1/2-inch drive, 0-250 foot-pounds (0-339 Newton-meters)
8. Torque wrench – 3/8-inch drive, 0-600 inch-pounds (0-50 Newton-meters)
9. 1/2 inch and 3/8-inch drive ratchets
10. Battery operated impact wrench with a 3/8-inch adapter and a 1/2-inch adapter
11. 6-millimeter ball point hex socket with 3/8-inch drive
12. 6-inch adjustable wrench-with 15/16-inch capacity
13. T25 torque bit
14. Loctite Threadlocker Blue 242
15. Cleaning supplies (rags and 70% isopropyl alcohol)
16. Installation fixture
17. Duct or Genie lift
18. (2) 8-foot (2.5 meter) step ladders
19. Appropriate cart to transport equipment and tools

Additional Required Installation Tools (ZGHSA)

1. 1-1/8-inch socket with 1/2-inch drive
2. Force gauge capable of reading 3-4 lbs. (13-18 N)
3. 1/4-inch hex socket with 3/8-inch drive

Additional Required Installation Tools (ZGCM-48 | ZGCM-66)

1. 15/16-inch socket with 1/2-inch drive

Additional Required Installation Tools (ZGCM-HSA)

1. 15/16-inch socket with 1/2-inch drive
2. 1/4-inch hex socket with 3/8-inch drive



May require additional tools to achieve torque specifications.

Installation – Floor Unit (ZGM-6-5H)

System Installation Sequence

1. Relocate all components to the surgical suite
2. Install the Boom Arm
3. Install the Docking Station
4. Install the Balancer
5. Install the End Stop Cap
6. Install the Body Shield Assembly
7. Attach the Shoulder Shields
8. Adjust the Balancer
9. Release Locked Balancer
10. Finalize the Installation

Relocate All Components to Surgical Suite (Figure 6)



CAUTION! INJURY RISK

Zero-Gravity floor unit is heavy. Use caution when handling the device.



CAUTION! PINCH POINT HAZARD

Never push or pull Zero-Gravity floor unit by placing hands on large D-shape plate. Casters may swivel and pinch hands or fingers. Always use push handles to move Zero-Gravity system.



WARNING! TIP OVER HAZARD

Disassemble device prior to transport. Lower assembly to lowest height, remove body shield, remove balancer and remove boom arm.



WARNING! TIP OVER HAZARD

To relocate device in surgical suite: raise leveling feet; roll over flat surfaces with no obstructions.

Figure 6

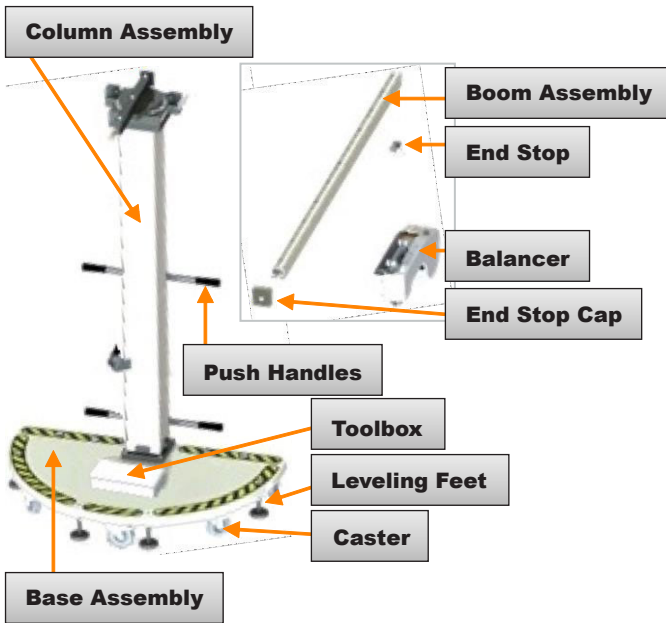

After uncrating, all components must be relocated to the surgical suite for assembly and installation.

1. Raise leveling feet clear of the floor to roll base and column assembly.
2. Roll base to an open area where the boom may be assembled without interference from other equipment.
3. Once in position, lock casters to prevent base from moving.

Install the Boom

The boom arm mount is shipped with a top plate attached (Figure 7). The top plate must be removed.

Figure 7

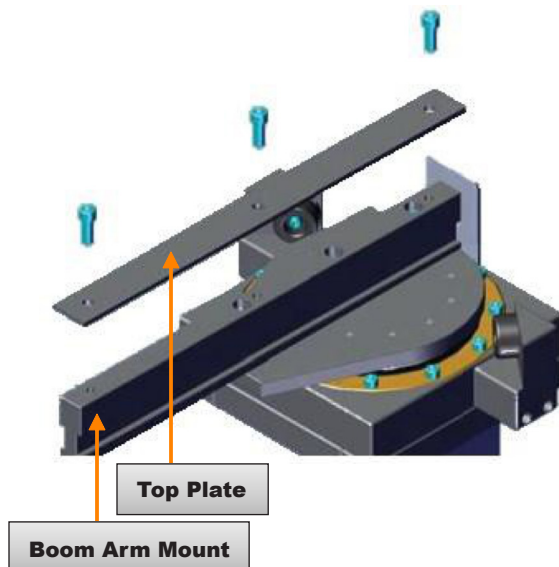

1. While standing on a ladder, remove the top plate by removing (3) 3/8-16 x 1-inch long screws using 5/16-inch hex wrench. Set the screws aside for use in step 4.

Figure 8

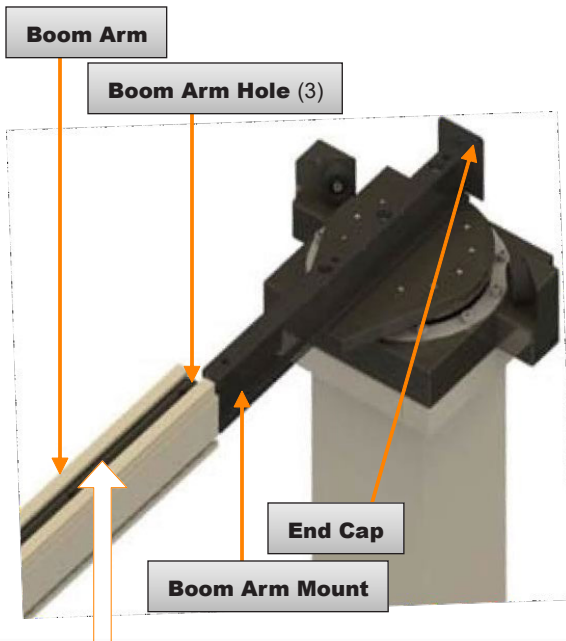

**Top Plate is inserted into Boom Arm
Align (3) holes in Top Plate with (3) Holes in Boom Arm**

2. Slide the top plate into the end of the boom arm, aligning both sets of (3) holes. (Figure 8).
3. Slide the boom arm, containing top plate, onto the boom arm mount until it touches the end cap (Figure 8).

4. Attach the boom arm using the (3) 3/8-16 x 1-inch long screws previously removed in step 1. (Figure 9)

Figure 9

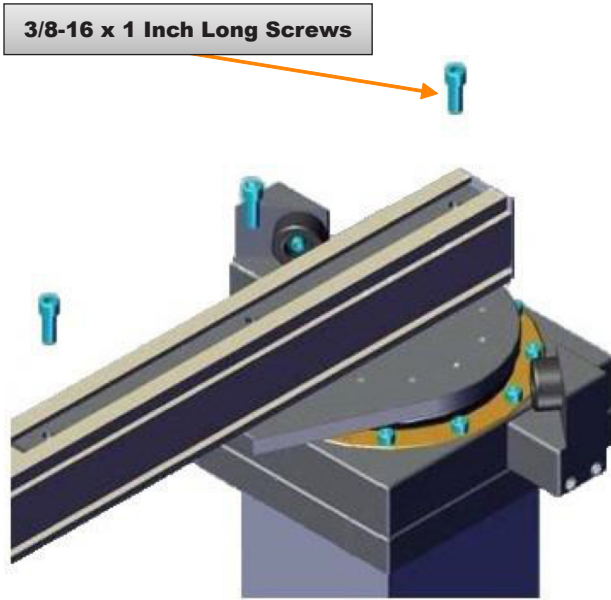

ATTENTION! Ensure screws are tightened securely.

Install Docking Station

Figure 10

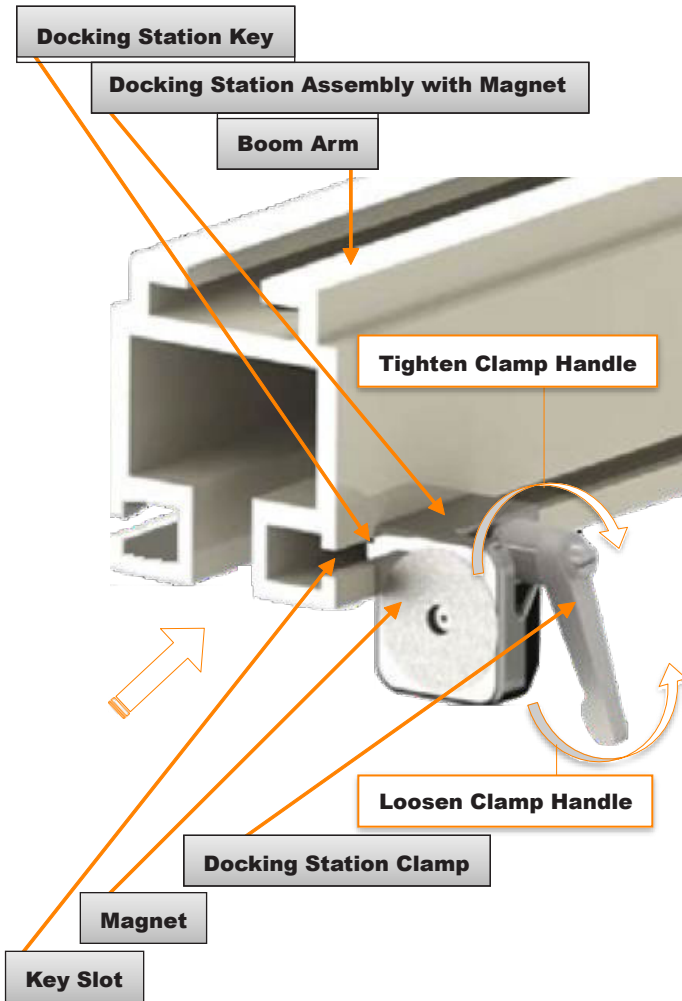

1. Rotate the clamp handle counterclockwise to loosen and insert docking station assembly on right side of the open end of boom arm. Align docking station key into boom arm key slot with magnet facing away from the open end of boom (Figure 10)
2. Position docking station assembly at end of key slot approximately 12 inches (30.5 centimeters) from the Column assembly and rotate clamp handle clockwise to tighten.

Install Balancer



WARNING! INJURY RISK

Balancer is mounted to a wheeled trolley and is free to roll. During disassembly, boom arm end stop cap is removed and balancer can easily roll and fall out of boom arm.

Do not leave balancer unattended while end stop cap is removed.



Do not release balancer cable unless the clamp stop is securely fastened and tightened to the body shield frame.

1. Slide the balancer into large opening on table end of the boom arm. Move balancer to engage docking station.
2. Install balancer round-end first. (Figure 11)

Figure 11

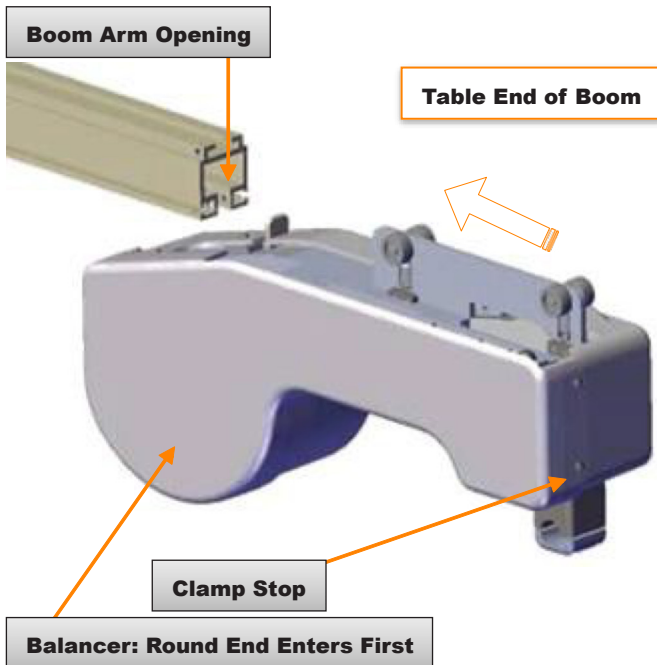

Install End Cap

Figure 12

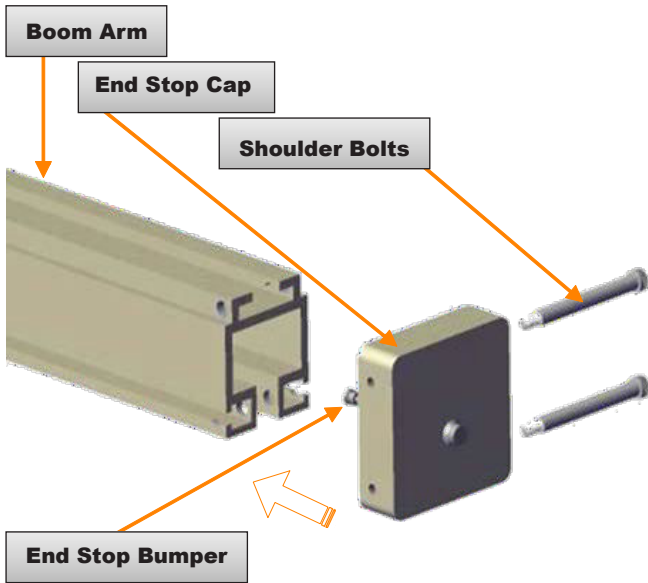

1. Remove shoulder bolts from end stop cap and slide the end stop cap assembly over end of the boom arm (Figure 12).
2. Using a 5/32-inch hex wrench, install (2) 5/16-18 X 2-3/4-inch-long shoulder bolts. Torque to 138 inch-pounds (11.5 foot-pounds) (15.6 Newton-meters) maximum (Figure 12).

ATTENTION! Ensure shoulder bolts are tightened securely.



WARNING! INJURY RISK-CABLE HAZARD:
Annual inspections must be performed on the cable. Cables must be replaced if there are signs of wear.

For systems manufactured before application of this guide:



WARNING! INJURY RISK-CABLE HAZARD
Excessive rotation of Body Shield may cause Balancer Cable to break. The Body Shield must be lowered and allowed to unwind after each use, in an unlocked position. Annual inspections must be performed on the cable. Cables must be replaced if there are signs of wear.

Install Body Shield Assembly

Figure 13

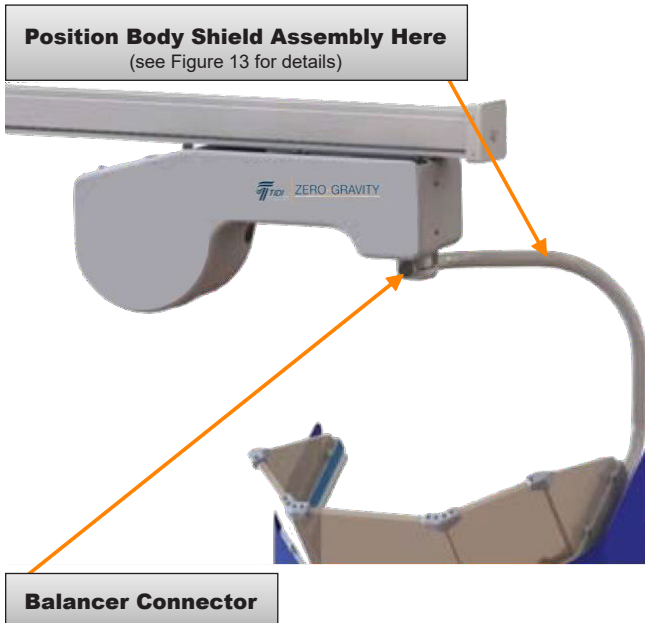

1. Place a clean cloth on the floor below the balancer cable and position body shield assembly on it. Loosen (4) balancer connector screws then align body shield frame with clamp hole in balancer connector on end of balancer cable (Figure 13).

2. Slide body shield assembly into balancer connector and position 1 inch (2.5 centimeters) from end of tube (Figure 14)
3. Tighten balancer connector screws using 5/32-inch hex wrench.

Figure 14

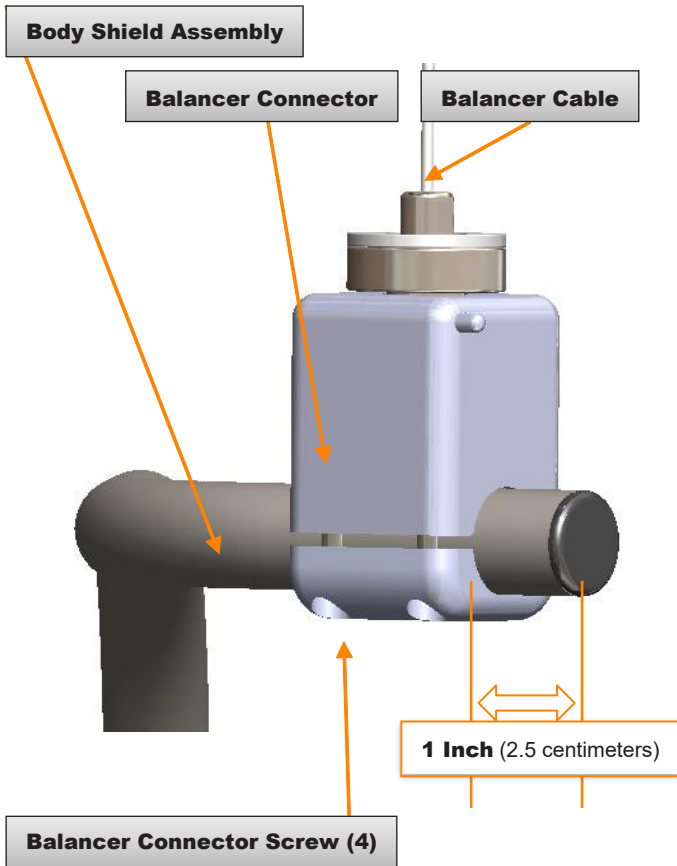

Tighten screws in opposite corners (one rotation each) until tight.

ATTENTION!

Ensure Body Shield assembly is tightly secured in balancer connector and Body Shield is hanging vertically (not tilted).

Attach Shoulder Shields

1. Add shoulder shields to mounting arms (Figure 15)

Figure 15

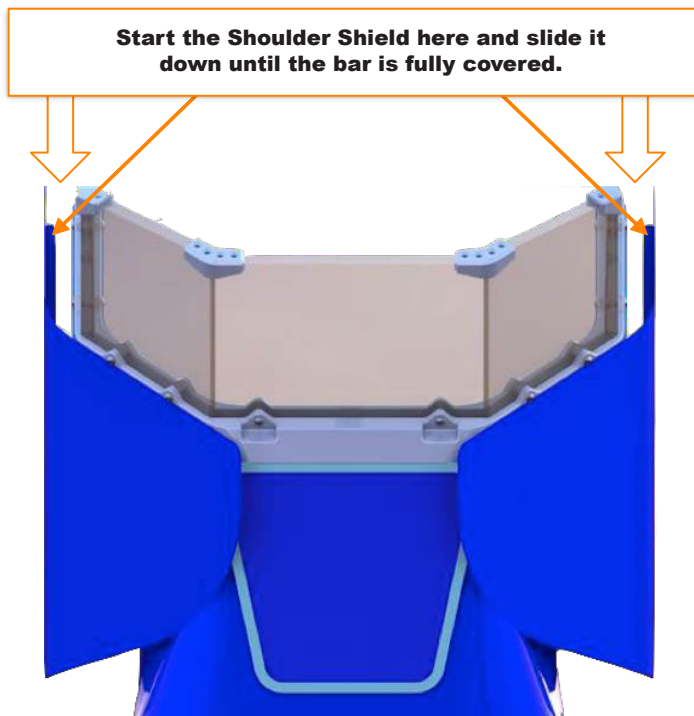

Adjust Balancer

1. With body shield secured to balancer cable, pull shield down 6-8 inches (15.2 – 20.3 centimeters) and release to test the balance. If shield stays in position, no further action is required. Go to step 4.
2. If shield drifts up or down, balancer needs further adjusting. Go to step 3.
3. With 17-millimeter socket, adjust balancer by turning nut clockwise (+) for more lift and counterclockwise (-) for less lift (Figure 16).
4. Move body shield up and down several times allowing balancer spring to adjust to new settings.
5. Install Cable Lock plug after adjustments.

Figure 16

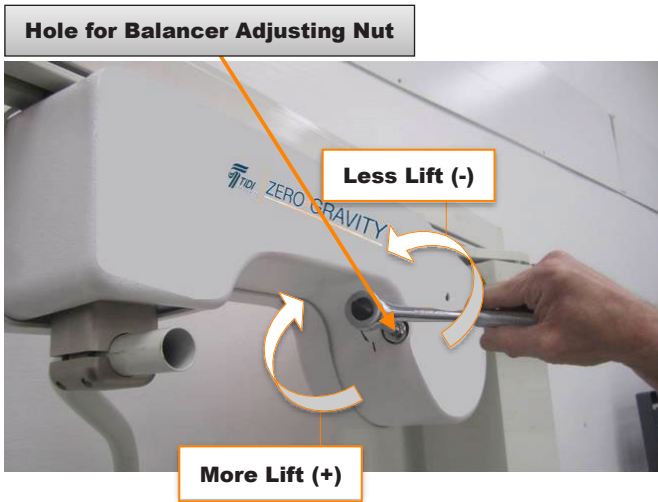

Balancer Installation Safety

- Balancers are shipped with a cable locking screw always set to unlocked.
- A spring balancer in an unlocked position constantly applies ~ 54 pounds (24.5 kilograms) of force to balancer connector when body shield is not attached.
- To extend and lock balancer cable, one person pulls on balancer connector to extend cable with both hands while another person rotates lock screw on balancer.



WARNING! INJURY RISK

When extending cable from balancer (with body shield not attached), personnel must maintain control of the spring-loaded cable at all times. Failure to maintain control of cable under spring tension can cause serious injury or property damage.

Option: Balancer Installation with Locked Cables

Some people may prefer installing body shield assembly to balancer by extending and locking cable to avoid reaching overhead.

- With great care, pull and extend balancer connector to desired distance and rotate lock screw with a flat blade screwdriver as shown in Figure 17.
- Attach body shield to balancer per Install Body Shield Assembly (above).
- Adjust balancer per Adjust Balancer (above).



WARNING! INJURY RISK – BALANCER CABLE

Unlocking balancer lock screw without body shield attached can cause severe injury. If the body shield is not attached, the Zero-Gravity balancer cable may rapidly retract in an uncontrolled manner.

Release Locked Balancer



It is recommended that a second person hold body shield assembly up while balancer lock screw is released. Body Shield Assembly may be released once balancer lock screw is released.



*Hold body shield assembly to remove slack in balancer cable. Balancer cable **MUST** be tight before releasing balancer lock. A loose cable may whip upward in an uncontrolled manner.*

1. While one person holds body shield assembly, a second person releases lock on balancer by inserting a flat blade screw driver into hole on side of balancer and rotating the Lock Screw as shown below in Figure 17.
2. Pull down on cable, then push screwdriver in and turn lock screw $\frac{1}{4}$ turn to unlock balancer, screw pops out when released. Weight of body shield is now supported by balancer cable.

Figure 17

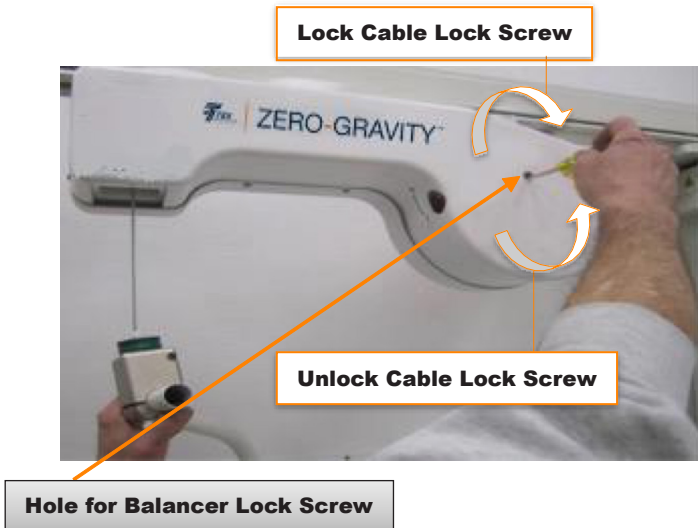

Finalize the Installation

Figure 18

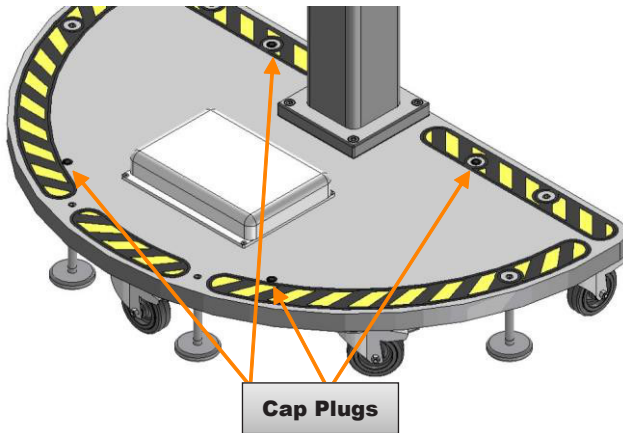

Do not remove and discard protective foam cover on Face Shield until in-service training.

1. Install cap plugs in (4) holes (Figure 18).
2. TIDI Products authorized installer must verify proper installation prior to clinical use by:
 - a. Verify and complete Installation Guide Checklist (next pages in this document)
3. TIDI Products authorized installer contacts TIDI Products service upon completion of installation and documentation.

ATTENTION!

Installation checklists are required as proof of system operational validation prior to clinical use.

Installation – Ceiling Mounted Unit (ZGHS | ZGCM-48 | ZGCM-66 | ZGCM-HSA)

System Installation Sequence (ZGHS)

1. Relocate All Components to Surgical Suite
2. Install Hinged Swing Arm Assembly
3. Install Drop Tube Assembly
4. Install Boom Arm Assembly
5. Install Balancer
6. Install Body Shield Assembly
7. Attach Shoulder Shields
8. Balancer Installation Safety
9. Adjust Balancer
10. Align Friction Brake & Adjust Bearing Tension
11. Adjust Ceiling Mount Bearing & Angle Limiting Stops
12. Install Support Plate Cover
13. Finalize Installation

System Installation Sequence (ZGCM-48 | ZGCM-66)

1. Relocate All Components to Surgical Suite
2. Install Rail
3. Install Drop Tube Assembly
4. Install Boom Arm Assembly
5. Install Carriage Covers
6. Install Optional Bumper
7. Install Balancer
8. Install Body Shield Assembly
9. Attach Shoulder Shields
10. Balancer Installation Safety
11. Adjust Balancer
12. Adjust Boom Arm Length
13. Adjust Boom Arm Angle
14. Finalize Installation

System Installation Sequence (ZGCM-HSA)

1. Relocate All Components to Surgical Suite
2. Install Rail
3. Install Drop Tube Assembly
4. Install Boom Arm Assembly
5. Install Carriage Covers
6. Install Balancer
7. Install Body Shield Assembly
8. Attach Shoulder Shields
9. Balancer Installation Safety
10. Adjust Balancer
11. Align Friction Brake & Adjust Bearing Tension
12. Finalize Installation

Relocate All Components to Surgical Suite (ZGHSA | ZGCM-48 | ZGCM-66 | ZGCM-HSA)



WARNING! RADIATION HAZARD

The Body Shield must be handled with care to avoid damage to the Body Shield protective lead material. If the Body Shield is damaged, it must be inspected according to the Body and Face Shield Fluoroscopy Inspection section of the User's Guide (TIDI Products document 84000).

The components that must be relocated to the surgical suite are:

- **ZGHSA:**
 - Support Plate Assembly
 - Drop Tube with Small Swivel Support
 - Boom Arm Assembly
 - Body and Face shield (do not remove protective face shield foam)
 - Right and Left Shoulder Shields
 - Balancer
 - Box containing the system components
 - Box containing the Vests
 - Box containing the Sterile Covers
 - Documentation Packet
- **ZGCM-48 | ZGCM-66:**
 - Boom Arm Assembly
 - Rail Assembly
 - Drop Tube
 - Body Shield (do not remove protective face shield foam)
 - Right and Left Shoulder Shields
 - Box containing the Balancer Assembly and Tool Kit
 - Box containing the Sterile Covers
 - Box containing the Vests
 - Box containing the kitted items:
 - Documentation Packet
- **ZGCM-HSA:**
 - Swivel Boom Assembly
 - Boom Arm Assembly
 - Rail Assembly
 - Drop Tube
 - Body Shield (do not remove protective face shield foam)
 - Right and Left Shoulder Shields
 - Box containing the Balancer Assembly and Tool Kit
 - Box containing the Sterile Covers
 - Box containing the Vests
 - Box containing the kitted items:
 - Documentation Packet

The Zero-Gravity Rail assembly must be placed in the operating room ceiling in a location that will provide the best access to the operating room table. Zero-Gravity placement is determined for operator access to patient on either

- a) one side of the operating table, or
- b) both sides of the operating table and is based upon the clinical procedures performed at the facility.

Every installation has a TIDI Products pre-determined placement plan identifying where to place Zero-Gravity in relationship to the operating table.

Contact TIDI Products at the TIDI service call number to obtain a copy of the placement plan.

DO NOT install Zero-Gravity in the room without a TIDI Products placement plan.

Install Hinged Swing Arm Assembly (ZGHSA)

Not all facilities use Unistrut® type ceiling support systems. In these cases, TIDI Products recommends using the supplied Hex Screws and Washers to secure the support plate to the ceiling. Fasteners used to support the Hinged Swing Arm must be grade A490 or better.



Use of fasteners other than those recommended by TIDI products should be approved by facility engineer of record and recorded.



WARNING! INJURY RISK-HEAVY EQUIPMENT

Use care when handling the Hinged Swing Arm Assembly. The Support Plate Assembly weighs approximately 200 pounds (90 kilograms) and must be handled using a mechanical lift.



It is recommended the installer use a minimum of two persons and or a mechanical lift, such as a duct lift or genie lift, to position, hold, and fasten the Support Plate to the ceiling.

1. Determine proper placement for the hinged swing arm according to TIDI Products placement plan.
2. The Support Plate can be mounted either above or below the Unistrut. See TIDI Products Placement Plan to determine which installation applies to the suite.
3. Place Zero-Gravity on an appropriate lift and raise it to the ceiling at height for attachment to the ceiling support structure.



The Hinged Swing Arm Assembly is to be mounted to the support structure on Unistrut metal framing (p5001 or equivalent). Unistrut Spring nuts and hex bolts are provided standard. See 18 and Figure 19.



Typically, operating room ceilings are level within 0.02 inch per 39 inches (0.5 mm per 1 meter). The Zero-Gravity requires this degree of level to achieve optimal operating conditions.



Shimming is typically required to properly level the Hinged Swing Arm Assembly. Shim between support structure and Support Plate Assembly of the Hinged Swing Arm Assembly as needed. Leveling blocks are included. See Figure 20.

Mount the Support Plate Above the Unistrut (Figure 19)

1. Thread Hex Screws into Channel Nuts (do not tighten at this time).
2. Use Inclinometer and Leveling Screws to level the Support Plate within 0.2 degrees along the width and length of the Support Plate.
3. After level is acquired, use shims between the Support Plate and Unistrut.
4. Torque Hex Screws to 100 foot-pounds (135 Newton-meters).

Figure 19

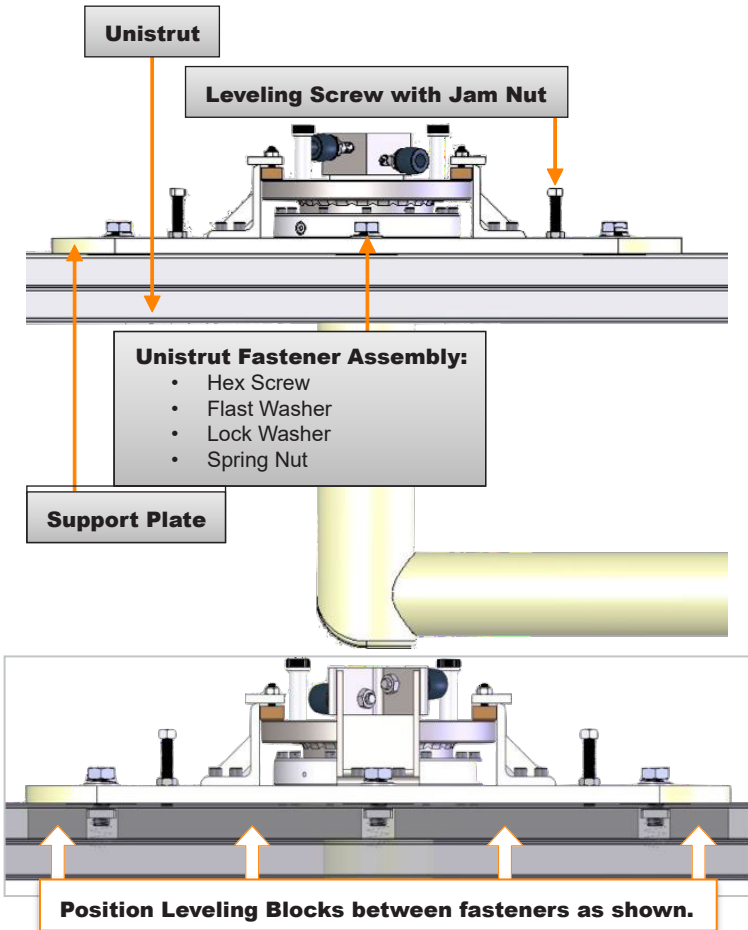

Mount the Support Plate Below the Unistrut (Figure 20)

1. Tighten Hex Screws into Channel Nuts. Use Inclinometer and Leveling Screws to level the Support Plate within 0.2 degrees along the width and length of the Support Plate. (Hex Screws may initially need loosened to acquire level.)
2. After level is acquired, use shims between the Support Plate and Unistrut.
3. Torque Hex Screws to 100 foot-pounds (135 Newton-meters) and tighten jam nuts on Leveling Screws.

Figure 20

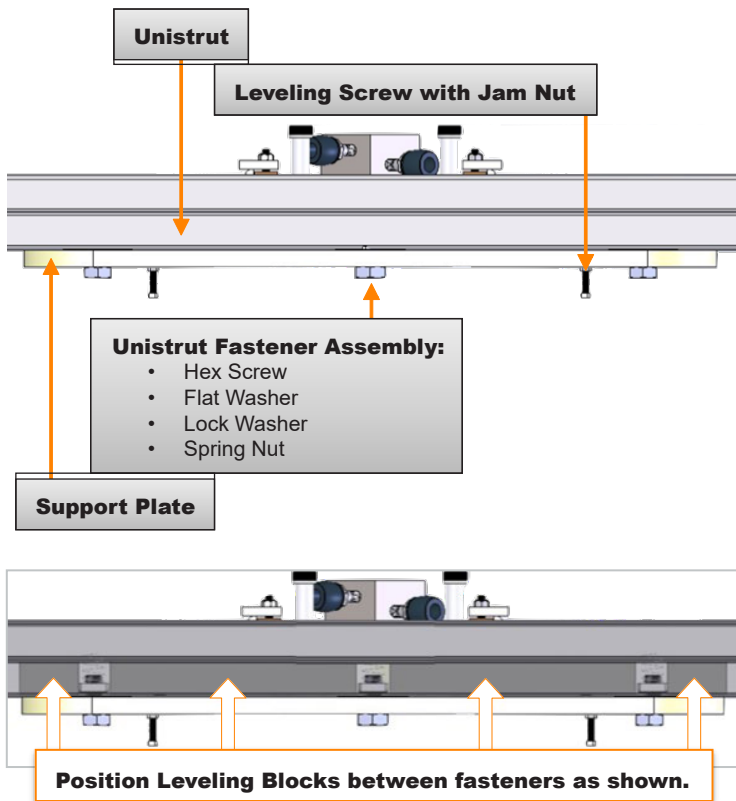

Shim the Support Plate

Whether mounting above the Unistrut or below the Unistrut, shim between Support Plate and Unistrut after level is acquired. (See Figure 21.)

Figure 21

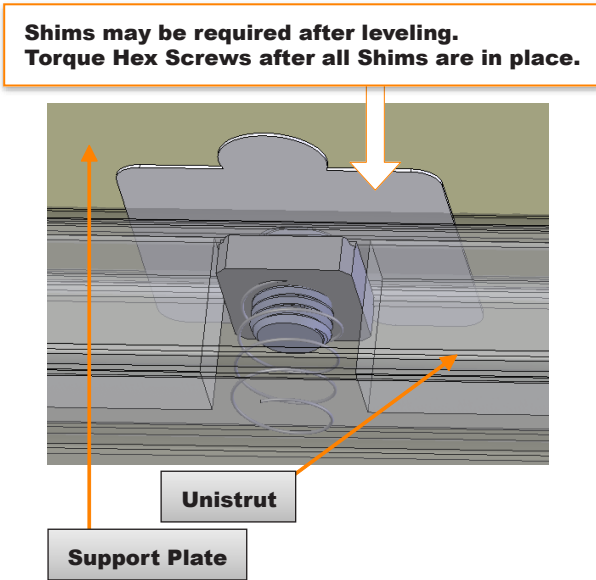

The Support Plate assembly must be level within 0.2°.

Install Rail (ZGCM-48 | ZGCM-66 | ZGCM-HSA)

Not all facilities use Unistrut® type support systems. In these cases, TIDI Products recommends using the supplied toe clamps and washers to clamp the rail to the ceiling. Fasteners used to support the Monorail must be grade A490 or better.



Use of fasteners other than those recommended by TIDI products should be approved by facility engineer of record, and recorded.



WARNING! INJURY RISK-HEAVY EQUIPMENT

Use care when handling the Rail Assembly. The Rail Assembly weighs ~ 150 pounds (68 kilograms) and must be handled by two or more people.



Do not remove Rail End Stops, allowing the Carriages to accidentally slide off the Rail. Ball bearings may be lost if the Carriages are removed.



It is recommended the installer use a minimum of two persons and or a mechanical lift, such as a duct lift or genie lift, to position, hold, and fasten the rail to the ceiling.

1. Determine proper placement for the monorail according to TIDI Products placement plan.
2. Place Zero-Gravity on an appropriate lift and raise it to the ceiling at an appropriate height for attachment to the ceiling support structure.

Mount to Unistrut® Metal Framing or Similar Ceiling Strut System

Figure 22

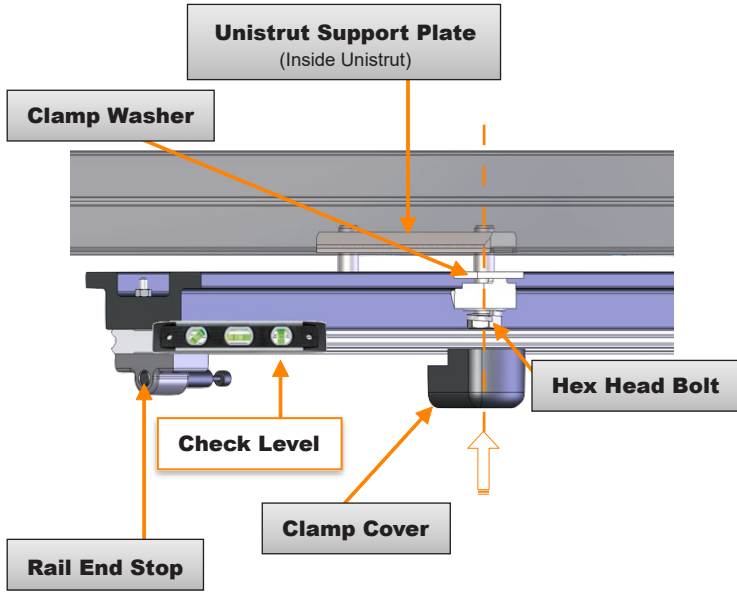

The Rail Assembly is to be mounted to the support structure on Unistrut metal framing (p5001 or equivalent). Unistrut Spring nuts and hex bolts are provided standard.



Typically, operating room ceilings are level within 0.02 inch per 39 inches (0.5 mm per 1 meter). The Zero-Gravity requires this degree of level to achieve optimal operating conditions.

3. Fasten Rail Assembly to Unistrut metal framing. Torque hex head bolts to 100 foot-pounds (135 Newton-meters) (Figure 22).
4. Attach Toe Clamp Covers by snapping them onto the Toe Clamps (Figure 22).



The Rail Assembly should be level within 0.2°.

Install Drop Tube Assembly (ZGHSA | ZGCM-48 | ZGCM-66 | ZGCM-HSA)

Figure 23 (ZGHSA)

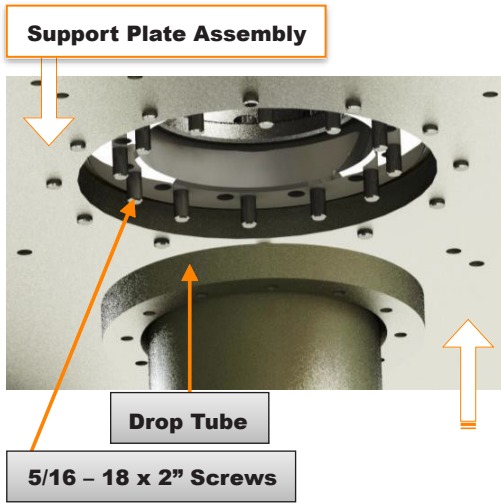

WARNING! INJURY RISK-HEAVY EQUIPMENT

Use care when handling the Drop Tube. The Drop tube weighs approximately 140 pounds (64 kilograms). Two or more people are required for handling.

1. Attach drop tube to support plate with (12) 5/16- 18 x 2-inch-long screws using a ¼ inch Hex Key Wrench. Apply Loctite Threadlocker Blue 242. Torque to 425 inch-pounds (35 foot-pounds) (48 Newton-meters) (Figure 23).



Ensure proper alignment prior to tightening screws.

Figure 24 (ZGCM-48 | ZGCM-66)

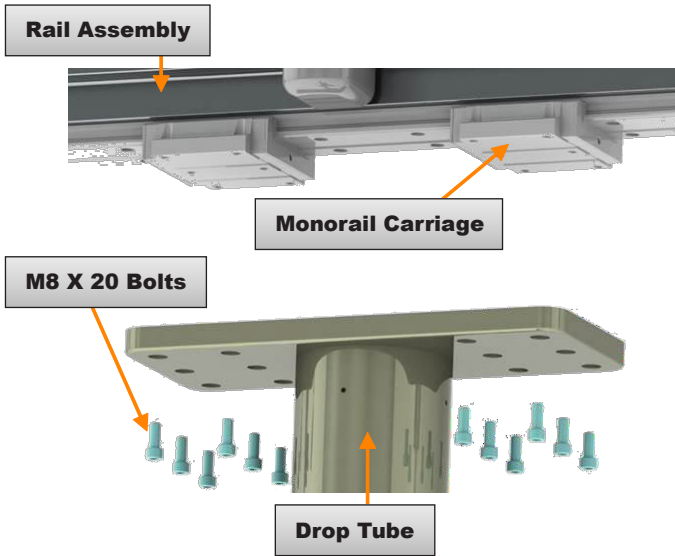

CAUTION! PINCH POINT HAZARD

Use care when moving the Carriage along the Rail Assembly. Fingers or hands can be pinched between the moving Carriage and the Rail End Stops.

1. Apply Loctite Threadlocker Blue 242 to (12) supplied M8 X 20-millimeter bolts and use bolts to attach the Drop Tube to Monorail Carriage using a 6-millimeter hex key. Torque to 269 inch-pounds (22.4 foot-pounds) (30 Newton-meters) maximum (Figure 24).



Ensure proper alignment prior to tightening screws.

Figure 25 (ZGCM-HSA)

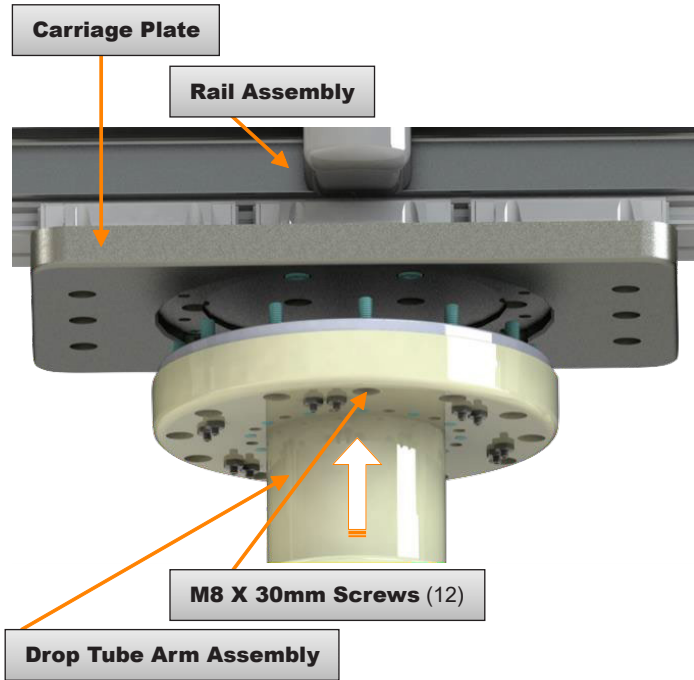

CAUTION! PINCH POINT HAZARD

Use care when moving the Carriage along the Rail Assembly. Fingers or hands can be pinched between the moving Carriage and the Rail End Stops.

1. Apply Loctite Threadlocker Blue 242 to (12) supplied M8 X 30-millimeter bolts and use bolts to attach the Drop Tube Arm to Carriage Plate using a 6-millimeter hex key. Torque to 350 inch-pounds (29 foot-pounds) (39 Newton-meters) (Figure 25).



Ensure proper alignment prior to tightening screws.

Install Boom Arm Assembly (ZGHSA | ZGCM-48 | ZGCM-66 | ZGCM-HSA)



CAUTION: Heavy Equipment

Use care when handling the Boom Arm assembly. The Boom Arm assembly weighs ~ 40 pounds (18 kilograms) for the ZGM-6-5H, ZGHSA, ZGCM-HSA and ZGCM-48, and the ZGCM-66 weighs ~50 pounds (23 kilograms). Two people are required for handling.



Ensure proper alignment prior to tightening screws.

Figure 26 (ZGHSA | ZGCM-HSA)

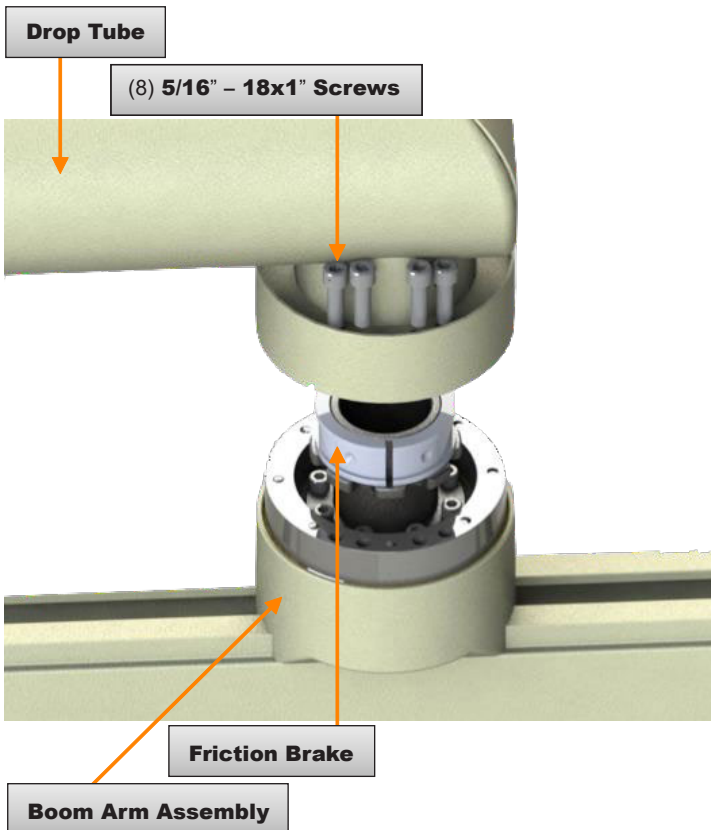

1. Ensure Brake Shoe is on Boom Arm Assembly (Figure 26).
2. Attach Boom Arm Assembly to Drop Tube with (8) 5/16-18 X 1-inch long screws using a 1/4-inch Hex Key Wrench. Apply Loctite Threadlocker Blue 242. Torque to 425 inch-pounds (35 foot-pounds) (48 Newton-meters) (Figure 26).

Figure 27 (ZGCM-48 | ZGCM-66)

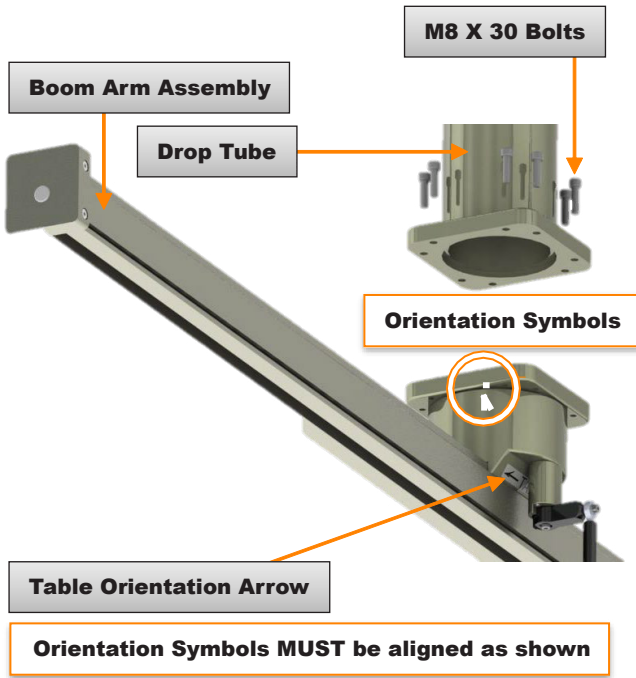

1. Attach the Boom Arm Assembly to the Drop Tube using (8) M8 X 30-millimeter screws using a 6-millimeter hex key. Apply Loctite Threadlocker Blue 242. Torque to 350 inch-pounds (29 foot-pounds) (39 Newton-meters) maximum (Figure 27).

ATTENTION!

Pay strict attention to orientation of the Boom Arm Assembly in relation to the surgical table. Orientation arrows **MUST** be aligned, and Table arrows **MUST** be pointing to the surgical table. Zero-Gravity will not function properly if mounted in the wrong orientation.

Figure 28 (ZGCM-48 | ZGCM-66)

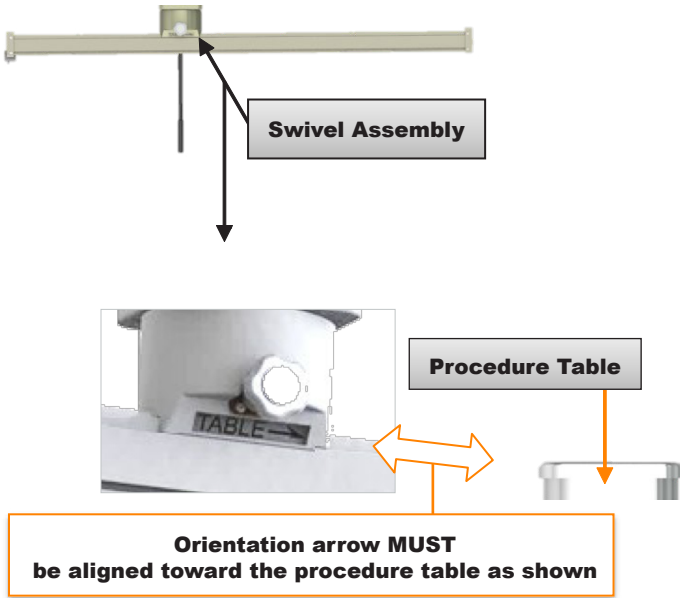

Install Carriage Cover (ZGCM-48 | ZGCM-66 | ZGCM-HSA)

Figure 29 (ZGCM-HSA)

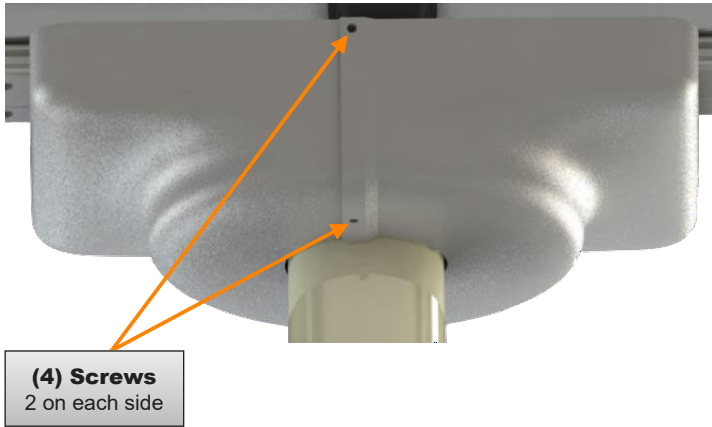

1. Attach the Carriage Cover using (4) 10-32 X 1/2-inch-long panhead Phillips screws.

Figure 30 (ZGCM-48 | ZGCM-66)

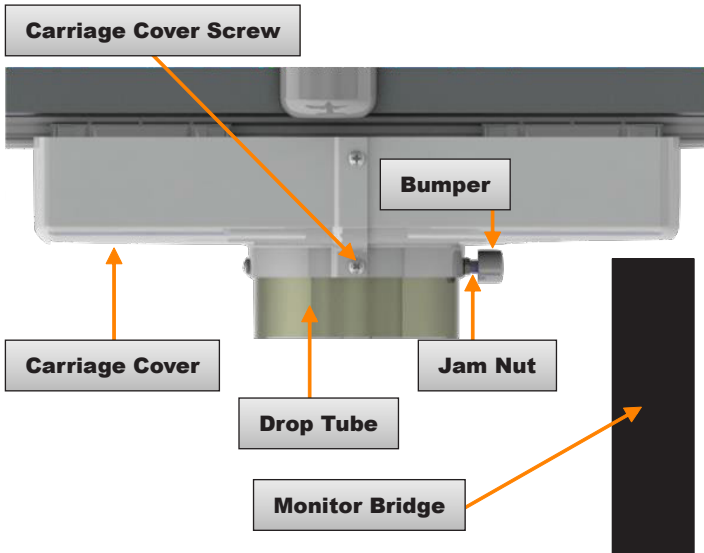

1. Attach the Carriage Covers using (6) 10-32 X 1/2-inch-long button head screws.

Install Optional Bumper (ZGCM-48 | ZGCM-66) (Figure 30)



The Optional Bumper prevents collisions between the Drop Tube and the Monitor Bridge.

1. If installing the Optional Bumper, remove the Carriage Cover Screw that faces the Monitor Bridge.
2. Replace the Carriage Cover Screw with the Optional Bumper. Screw the Optional Bumper in all the way until it contacts the jam nut.
3. Tighten the jam nut.



The Optional Bumper must be installed into the Drop Tube so that the supplied Jam Nut is tightened flush with the Carriage Cover.

Install Balancer (ZGHSA | ZGCM-48 | ZGCM-66 | ZGCM-HSA)



WARNING! INJURY RISK

Balancer is mounted to a wheeled Trolley and is free to roll. During assembly, Boom Arm End Stop Cap is removed and Balancer can easily roll and fall out of Boom Arm.

Do not leave Balancer unattended while End Stop Cap is removed.



CAUTION! PINCH POINT HAZARD

Use care when moving the Balancer along the Boom with the Trolley. Fingers or hands can be pinched between the moving Trolley and End Stops.



The End Stop Cap on the side of the Boom that will have the Procedure Table under it must be removed to install the Balancer.

Figure 31

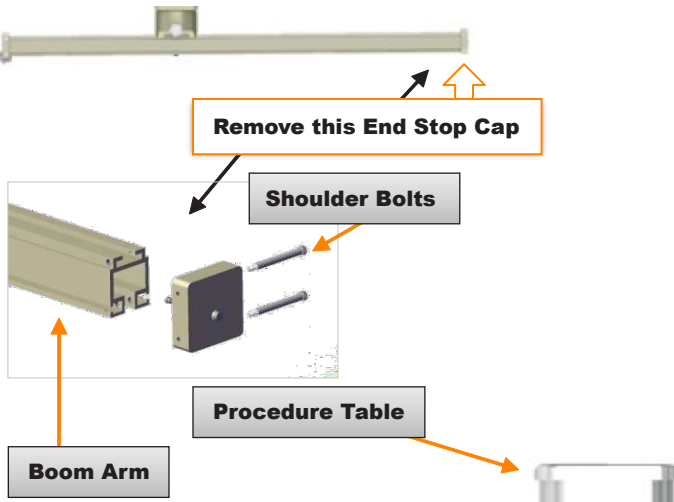

1. Remove the End Stop Cap by removing shoulder bolts from End Stop Cap using a 5/32-inch Hex Key Wrench and sliding the End Stop Cap assembly off the end of the Boom Arm (Figure 31).
2. Slide the Balancer into the Boom Arm opening. Move Balancer to engage Docking Station so the Balancer Tab is on the same side of the Boom as the Docking Station (Figure 32).
3. Replace the End Stop Cap over end of the Boom Arm and replace shoulder bolts (Figure 32).

Figure 32

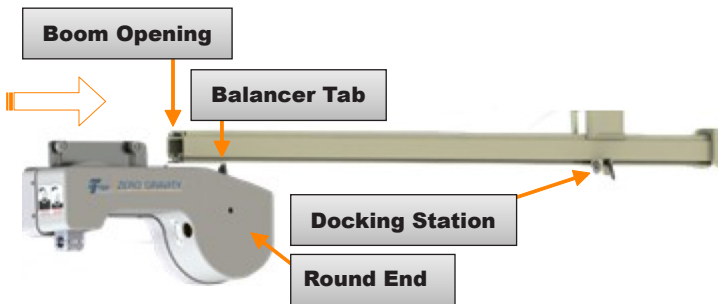

ATTENTION! Ensure shoulder bolts are tightened securely.

Install Body Shield Assembly (ZGHSA | ZGCM-48 | ZGCM-66 | ZGCM-HSA)



WARNING! RADIATION HAZARD

The Body Shield must be handled with care to avoid damage to the Body Shield protective lead material. If the Body Shield is damaged, it must be inspected according to the Body Shield and Face Shield Fluoroscopy Inspection section of the User's Guide (TIDI Products document 84000).



WARNING! INJURY RISK-CABLE HAZARD

Annual inspections must be performed on the cable. Cables must be replaced if there are signs of wear.

For systems manufactured before application of this guide:



WARNING! INJURY RISK-CABLE HAZARD

Excessive rotation of Body Shield may cause Balancer Cable to break. The Body Shield must be lowered and allowed to unwind after each use, in an unlocked position. Annual inspections must be performed on the cable. Cables must be replaced if there are signs of wear.



Do not remove the protective foam cover or vinyl protective shields from the face shield.

Figure 33

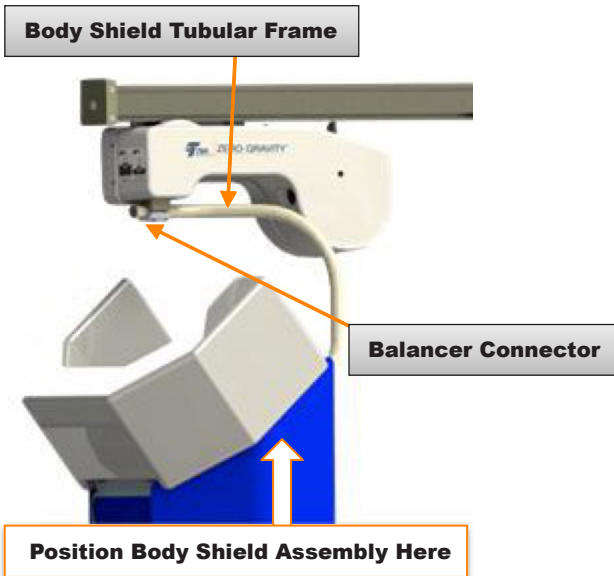

1. Loosen (4) Balancer Connector Screws, carefully lift the Body Shield Assembly, then align Body Shield Tubular Frame with clamp hole in Balancer Connector (Figure 34).
2. Slide Body Shield assembly into Balancer Connector and position 1 inch (2.5 centimeters) from end of the Body Shield Tubular Frame (Figure 34).
3. Tighten Balancer Connector Screws evenly using 5/32-inch hex wrench. Torque to 55 inch-pounds (4.5 foot-pounds) (6.2 Newton-meters).

Figure 34

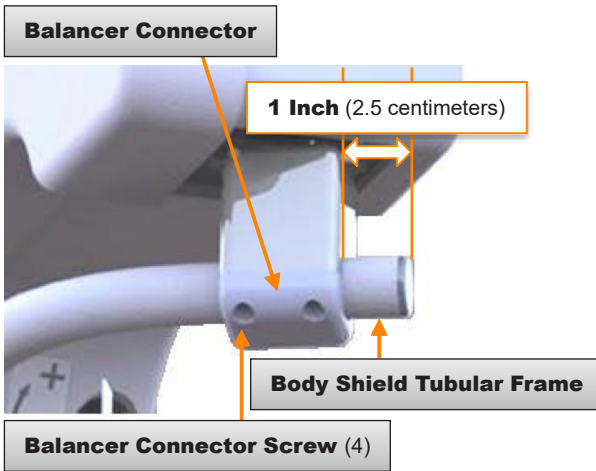

Tighten screws in opposite corners, one rotation each, until tight.

Figure 35



ATTENTION!

Ensure Body Shield assembly is tightly secured in Balancer Connector and Body Shield is hanging vertically (not tilted).

Attach Shoulder Shields (ZGHSA | ZGCM-48 | ZGCM-66 | ZGCM-HSA)

1. Add Shoulder Shields to mounting arms (Figure 36).

Figure 36

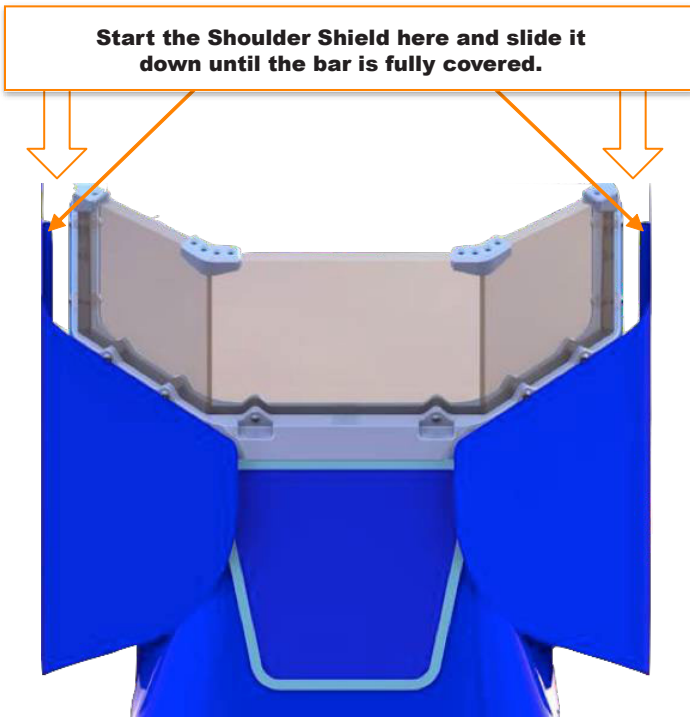

Balancer Installation Safety (ZGHSA | ZGCM-48 | ZGCM-66 | ZGCM-HSA)

- Balancers are shipped with a cable locking screw always set to unlocked.
- A spring balancer in an unlocked position constantly applies ~ 54 pounds (24.5 kilograms) of force to balancer connector.
- To extend and lock balancer cable, one person pulls on balancer connector to extend cable with both hands while another person rotates lock screw on balancer.



WARNING! INJURY RISK

When extending cable from balancer (with body shield not attached), personnel must maintain control of the spring loaded cable at all times. Failure to maintain control of cable under spring tension can cause serious injury or property damage.



WARNING! INJURY RISK – BALANCER CABLE

Unlocking balancer lock screw without body shield attached can cause severe injury. If the body shield is not attached, the Zero-Gravity balancer cable may rapidly retract in an uncontrolled manner.

Adjust Balancer (ZGHSA | ZGCM-48 | ZGCM-66 | ZGCM-HSA)



CAUTION! EQUIPMENT DAMAGE RISK

Attempting to adjust the Balancer assembly while the cable locking screw is locked will cause permanent internal damage to the Balancer and inability to balance the Body Shield.



The Balancer is adjusted at the factory. However, fine adjustments may be required at the time of installation.



Do not make adjustments unless the Shoulder Shields are installed properly (Figure 36) and the protective foam is removed from the Face Shield. Replace Protective Foam after adjustments.



If shield drifts up or down, balancer needs further adjusting.

Figure 37

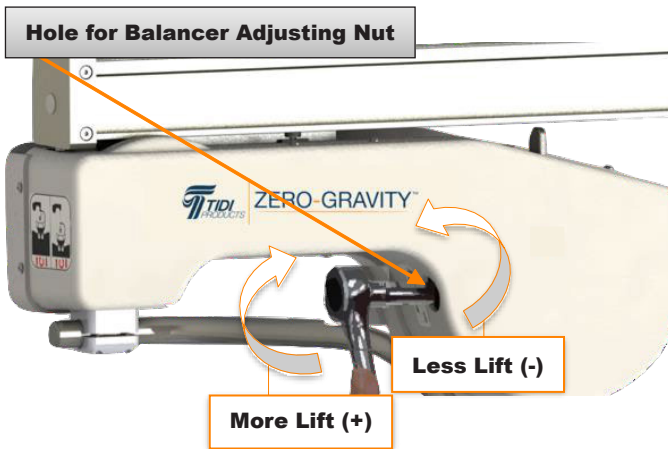

1. With body shield secured to balancer cable, pull shield down 6-8 inches (15 – 20 centimeters) and release to test the balance. If shield stays in position, no further action is required.
2. With 17 millimeters socket, adjust balancer by turning nut clockwise (+) for more lift and counterclockwise (-) for less lift (Figure 15).
3. Move Body Shield up and down several times allowing Balancer spring to adjust to new settings.

Align Friction Brake & Adjust Bearing Tension (ZGHSA | ZGCM-HSA)

Align Friction Brake Set Screws with Friction Brake (Figure 38)

1. Rotate Boom Arm until red dots are visible in all three Set Screw holes (third hole located on backside).
2. Thread Set Screws into holes until contact to Friction Brake is made.
3. Thread Jam Nuts onto Set Screws. (Do Not Tighten at This Time)

Figure 38

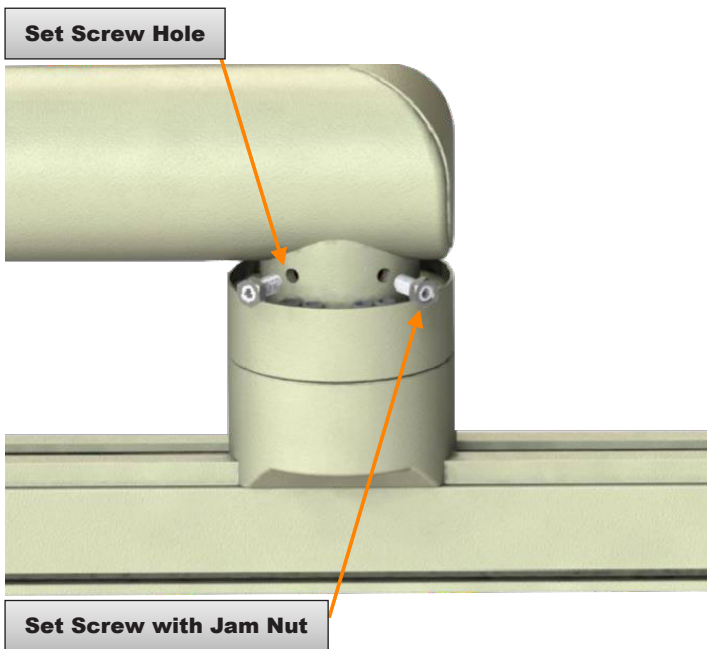

Adjust Bearing Tension (Figure 39)

1. To add more tension on the bearing, use a crescent wrench to loosen (turn counterclockwise) the jam nut and rotate the adjustment screw clockwise (to the right).
2. To reduce tension on the bearing, use a crescent wrench to loosen (turn counterclockwise) the jam nut and rotate the adjustment screw counterclockwise (to the left).
3. Retighten the jam nut.



Adjustment Screws should be tightened evenly. Small incremental turns should be made on each screw.

Figure 39

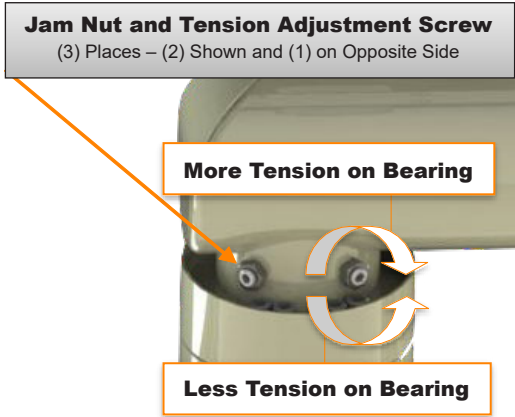

4. Apply Boom Assembly push force test at the end stop cap furthest from the swivel. Force should be between 3 and 4 pounds (1.4 and 1.8 kilograms) of resistance (Figure 40).

Figure 40

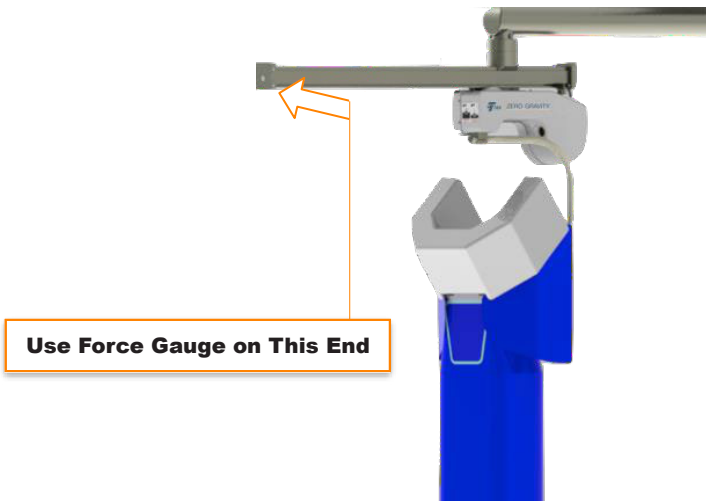

(Ensure Body Shield is directly under Swivel as shown to perform force test.)

Adjust Ceiling Mount Bearing & Angle Limiting Stops (ZGHSA)

Adjust Ceiling Mount Bearing Angle Limiting Stops (Figure 41)

The Swivel Stops and Swivel Bumpers will prevent interferences between the Hinged Swing Arm Assembly and other items in the room by stopping rotation before the interference occurs. To adjust the Swivel Stops and Swivel Bumpers (Figure 41):

1. Remove both Swivel Stops by turning them counterclockwise (to the left).
2. Rotate the Hinged Swing arm clockwise (to the right) until it reaches the end of needed rotation or it approaches a potential interference.
3. Install one of the Swivel Stops in the nearest indexing hole. Torque to 283 foot-pounds (384 Newton-meters).
4. Perform finer adjustment, as needed, by turning the Swivel Bumper.
5. Repeat steps 2, 3 and 4 using counterclockwise rotation.
6. Tighten jam nuts after stop locations have been established

Figure 41

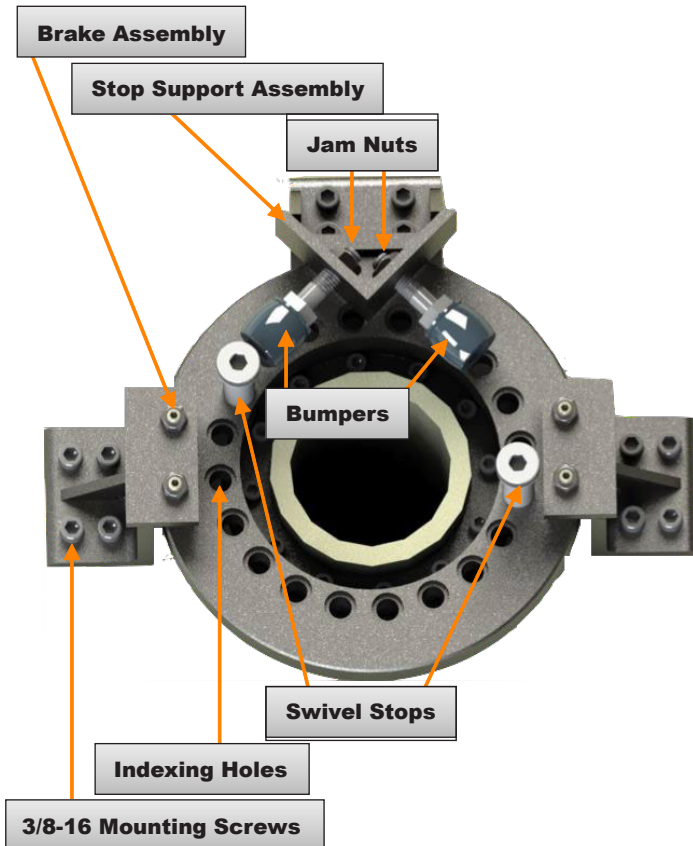

Adjust Minimum Clearance (Figure 42)

Set Bumpers to ensure end of Drop Tube Arm stops before interference occurs with walls or other equipment in the suite.

Figure 42

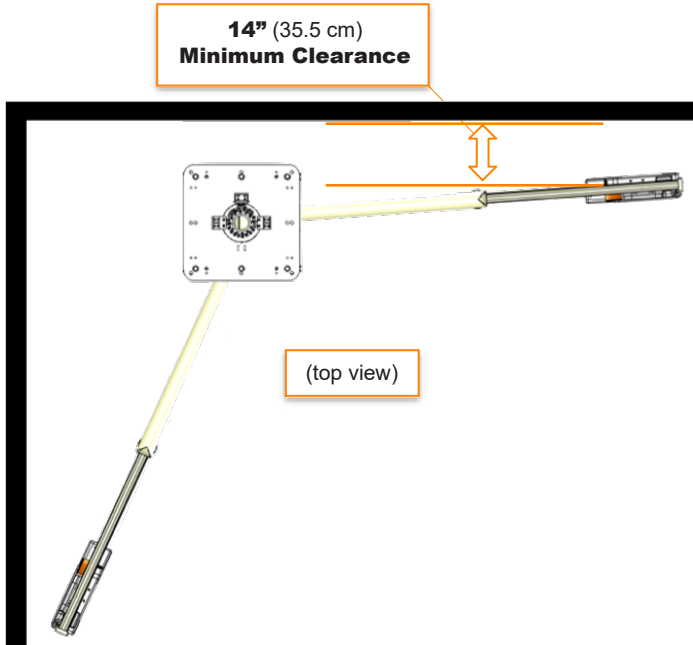

Brake Assembly and Stop Support Assembly can be re-positioned radially around the swivel if required. Always place each Brake Assembly 180° opposite of each other and torque the 3/8-16 screws to 300 in-lbs. (33 Newton-meters) (Figure 41).

Adjust the Ceiling Bearing Tension (Figure 43)

1. To add more tension on the bearing, use a crescent wrench to loosen (turn counterclockwise) the jam nut and rotate the adjustment screw clockwise (to the right) using an Allen wrench.
2. To reduce tension on the bearing, use a crescent wrench to loosen (turn counterclockwise) the jam nut and rotate the adjustment screw counterclockwise (to the left) using an Allen wrench.
3. Retighten the jam nut.
4. Drop Tube push force at the swivel support end should be between 3 and 4 pounds (1.4 and 1.8 kilograms) of resistance.
5. Ensure jam nuts are tight after adjustments are made.

Figure 43

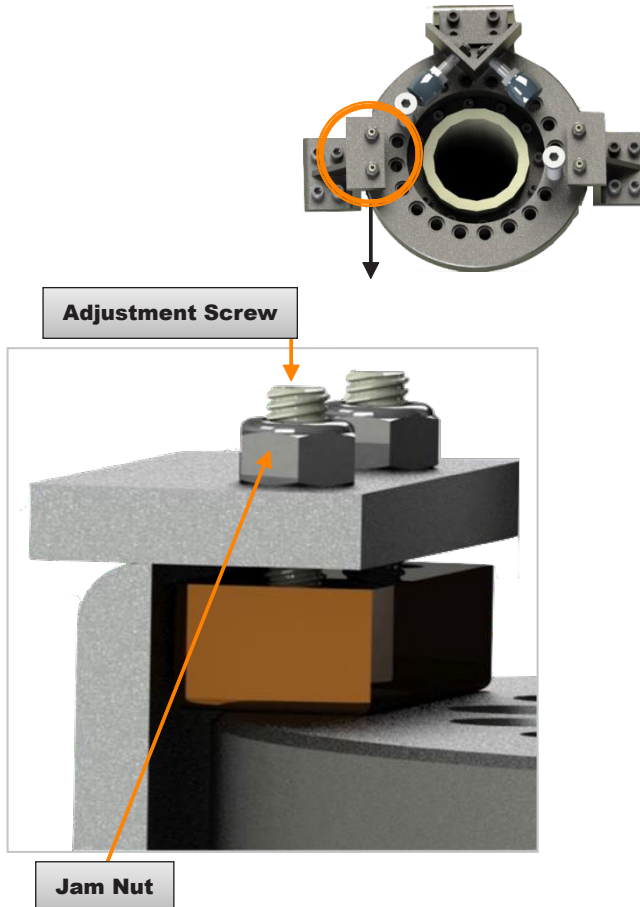

Install Support Plate Cover (ZGHSA)

There are two types of covers depending on the method of mounting the Support Plate. If the Support Plate is mounted on top of the Unistrut, see Figure 44. If the Support Plate is mounted below the Unistrut, see Figures 47 and 48.

Figure 44

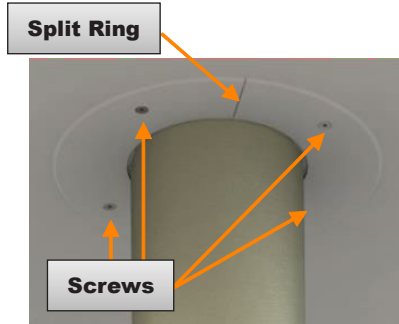

ABOVE THE UNISTRUT MOUNT (FIGURE 44)

Twist the split ring to position the cover around the Drop Tube and install (4) 8-32 X 1½ inch Screws. (Tabs are supplied to be positioned behind the ceiling panel to tighten the ring.)

Figure 45

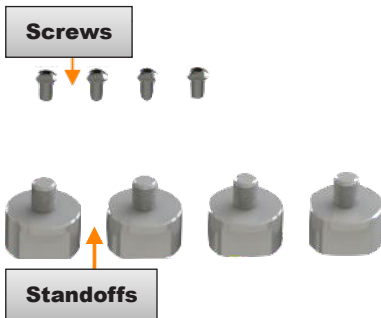
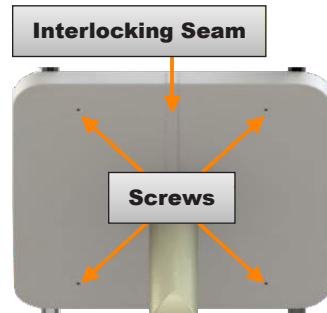

Figure 46



BELOW THE UNISTRUT MOUNT (FIGURE 45)

Screw Standoffs into the Support Plates corresponding Cover holes. Place the two-piece cover around the Drop Tube as shown. (The center seam is interlocking.) Install (4) 8-32 X ½ inch screws.

Adjust Boom Arm Length (ZGCM-66)



It may be necessary to slide the Boom to adjust the Zero- Gravity for additional reach or to avoid overhead collisions.



CAUTION! PINCH POINT HAZARD

Use care when sliding the Boom under the Swivel Center. Fingers or hands can be pinched between the Swivel and stop screws or the End Stop Cap in the top of the Boom.



CAUTION! EQUIPMENT DAMAGE RISK

The 66-inch-long Boom has stop screws to limit positioning. Travel is limited to avoid unsafe loading on the Boom. Do not remove the travel limiting screws (ZGCM-66 only).



WARNING! HANDLING PEOPLE HAZARD

Handling people with this equipment can cause severe injury. Do not use for lifting, lowering, or transporting people.

Figure 47

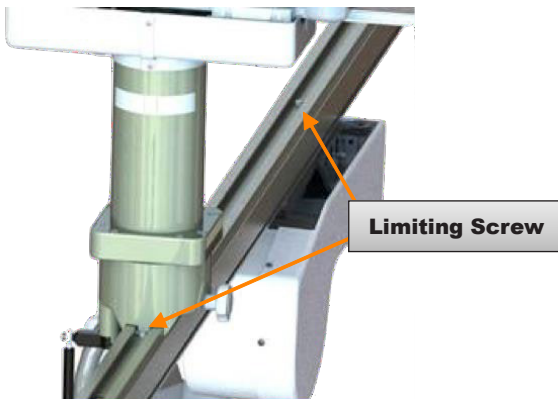
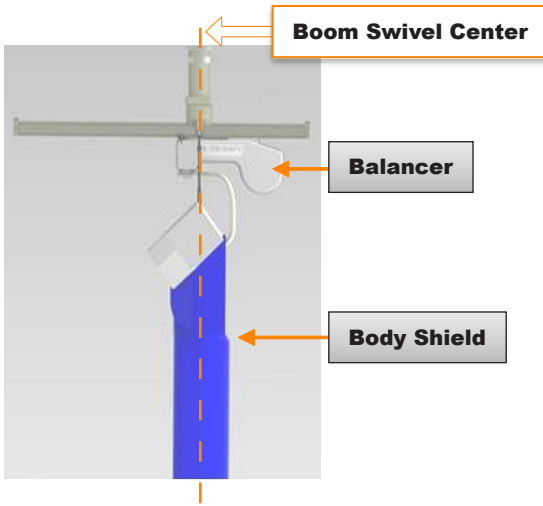
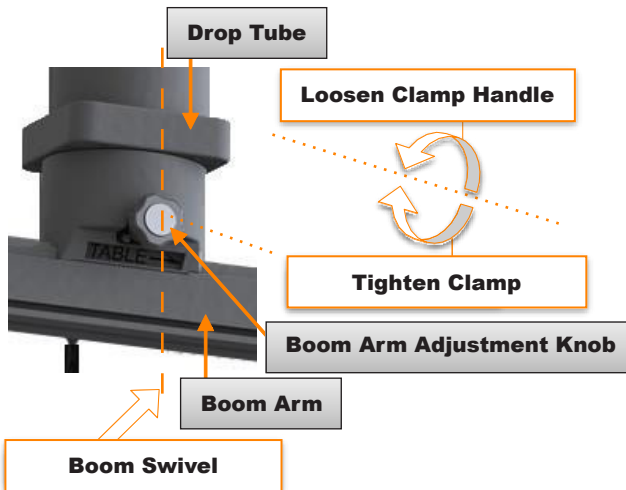

Figure 48



1. Slide Balancer and Body Shield directly under Swivel Center (Figure 48).
2. Unclamp Boom Arm Adjustment Knob by turning the knob on the side of the swivel in a counter-clockwise direction (Figure 49).
3. With one person lifting Balancer, other person slides Boom Arm to desired position.
4. Once positioned, clamp Boom Arm by turning knob in a clockwise direction (Figure 49).
5. Lower Balancer back onto Boom Arm.

Figure 49



Adjust Boom Arm Angle (ZGCM-48 | ZGCM-66)



WARNING! COLLISION RISK

Leaving Lock Pin in disengaged (unlocked ) position, while operating Boom Arm, may lead to collisions with other devices in operating room.

Figure 50



1. Slide Balancer and Body Shield under Boom Swivel Center. See Figure 48.
2. Pull the Pull Pin Handle down to disengage (unlock) Lock Pin and rotate handle 45° to lockout position. Release Pull Pin Handle. Boom will now rotate freely (Figure 50).
3. Place Boom Arm at desired angle (Figure 51). Pull down Pull Pin Handle again and rotate back to the center to lock Boom Swivel. Release Pull Pin Handle. Lock pin will reset. Gently move Boom Arm back and forth to ensure that Boom Swivel is locked again (Figure 50).

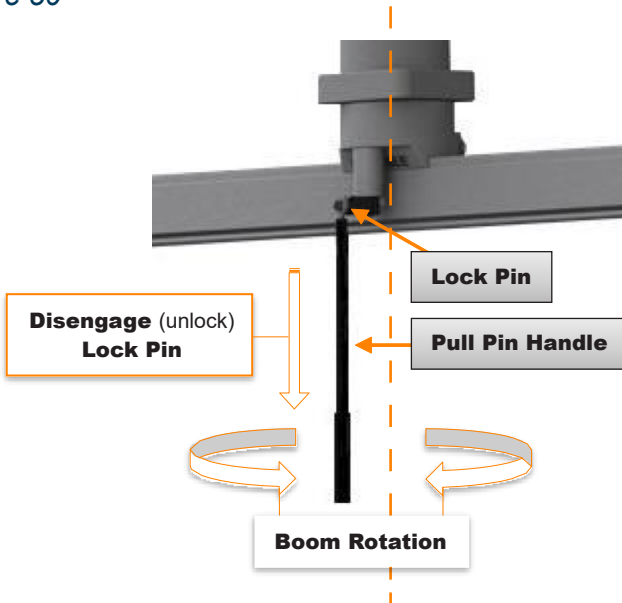

Users less than 5 feet-6 inches (168 centimeters) tall, may require a step stool to access Pull Pin Handle.

Figure 51



It is not possible to lock Boom in a position parallel to Rail Assembly.

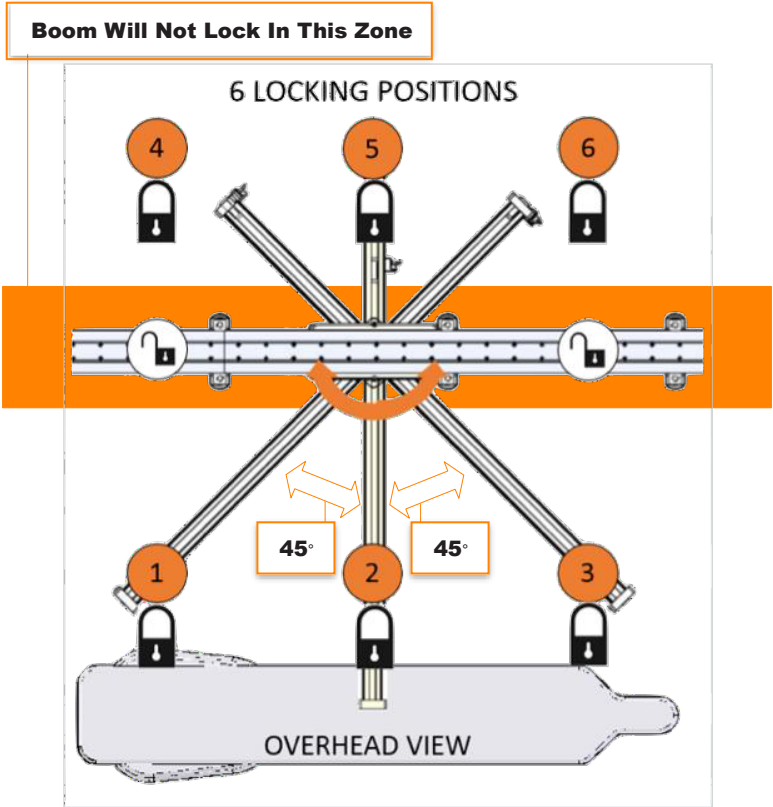

Finalize Installation (ZGHSA | ZGCM-48 | ZGCM-66 | ZGCM-HSA)



CAUTION! EQUIPMENT DAMAGE RISK

Do not remove and discard protective foam cover on Face Shield until in-service training.

1. Clean all surfaces to remove any fingerprints or grease marks from installation. See User's Guide (TIDI Products document 84000).
2. TIDI Products authorized installer must verify proper installation prior to clinical use by:
 - a. Verify and complete Installation Guide Checklist (next pages in this document)
3. TIDI Products authorized installer contacts TIDI Products service upon completion of installation and documentation.

ATTENTION!

Installation checklists are required as proof of system installation validation prior to clinical use.

THIS PAGE IS INTENTIONALLY LEFT BLANK

Zero-Gravity Floor Unit Checklist

ZGM-6-5H

NOTE: THIS IS SHEET 1 OF A 3-SHEET FORM

I hereby certify that this equipment/application/system is functionally acceptable at the current time and the following items have been checked and verified:

- The (3) boom arm attachment screws (3/8-16 x 1.00 inch long) are installed and tight.
- The (2) end stop cap shoulder bolts (5/16-18 x 2-3/4 inch long) are installed and tight.
- Confirm User's and Installation Guides are available in suite. If not, contact TIDI Products service at +1.920.751.4300. Hardcopies are supplied with each unit.
- Body Shield Assembly is tightly secured in Balancer Connector, and (4) screws are installed and torqued to 55 inch-pounds (6.2 Newton-meters).
- Balancer, swivel bearing, and boom arm operate freely and smoothly throughout range of motion.
- Balancer vertical travel is free and smooth throughout range of motion.
- Body shield is stationary when adjusted (no drift up or down).
- Zero-Gravity is located in the operating suite to provide adequate range of motion during use.
- Customer in-service (use, maintenance, inspection, etc.) training has been provided and understood.
- Review the importance of Annual inspection of Cable with service personnel.

Zero-Gravity Hinged Swing Arm Checklist

ZGHSA

NOTE: THIS IS SHEET 1 OF A 3-SHEET FORM

I hereby certify that this equipment/application/system is functionally acceptable at the current time and the following items have been checked and verified:

- (6) Hex head mounting bolts (5/8-11 x 2-3/4 inch long) are installed. Torque to 100 foot-pounds (135 Newton-meters).
- (12) Drop Tube mounting screws (5/16-18 x 2 inch long) are installed. Torque to 425 inch-pounds (35 foot-pounds) (48 Newton-meters).
- (8) Swivel mounting screws (5/16-18 x 1 inch long) are installed. Torque to 425 inch-pounds (35 foot-pounds) (48 Newton-meters).
- (2) End Stop Cap shoulder bolts (5/16-18 x 2-3/4 inch long) on each end of the Boom are installed and tight.
- Body Shield Assembly is tightly secured in Balancer Connector, and (4) screws are installed and torqued to 55 inch-pounds (6.2 Newton-meters).
- Body Shield hangs vertically (not tilted).
- Balancer, swivel bearing, and boom arm operate freely and smoothly throughout range of motion.
- Confirm User's Manual and Installation Guide are available in suite. If not, contact TIDI Products service at +1.920.751.4300. Hardcopies are supplied with each unit.
- Body Shield Assembly easily locks and unlocks into Balancer Assembly to steer the two joints of the Hinged Swing Arm.
- Balancer vertical travel is free and smooth throughout range of motion. Body Shield is stationary when adjusted (no drift up or down).
- Zero-Gravity is located in the operating suite per TIDI Products site plan specifications.
- Drop Tube and Boom Arm Force have been adjusted between 3 and 4 pounds and jam nuts are tightened on set screws.
- Rotational stops have been positioned to avoid collisions.
- Zero-Gravity has been wiped clean of any installation dirt and or oils according to User's Guide (TIDI Products document 84000). Do not clean acrylic glass.
- If Stop Support Assembly and Brake Assemblies were re-positioned, the 3/8-16 screws are torqued to 300 inch-pounds (25 foot-pounds) (33 Newton-meters).

Note: Alternative fasteners approved for use by engineer of record are recorded on sheet 2 of this 3-sheet form.

Zero-Gravity Monorail Installation Checklist

ZGCM-48 | ZGCM-66

NOTE: THIS IS SHEET 1 OF A 3-SHEET FORM

I hereby certify that this equipment/application/system is functionally acceptable at the current time and the following items have been checked and verified:

- (10) Toe Clamp mounting bolts (5/8-11 x 2-3/4 inches long) are installed and torqued to 100 foot-pounds (135 Newton-meters), or grade A490, or better, approved by the facility engineer of record and specified below.
- (10) Toe Clamp covers are securely snapped in place.
- (12) Drop Tube to Carriage mounting screws (M8 x 20 millimeters long) are installed and torqued to 269 inch-pounds (22.4 foot-pounds) (30 Newton-meters).
- (8) Boom Arm Assembly to Drop Tube mounting screws (M8 x 30 millimeters long) are installed and torqued to 350 inch-pounds (29 foot-pounds) (39 Newton-meters).
- Carriage Covers and Optional Bumper, if used, are installed and the mounting screws are installed and tightened securely.
- Confirm User's manual and Installation Guides are available in suite. If not, contact TIDI Products Sales at +1.920.751.4300. Hardcopies are supplied with each unit.
- Boom Arm Adjustment Knob is tight.
- (2) End Stop Cap shoulder bolts (5/16-18 x 2-3/4 inches long) on each end of the Boom are installed and tight.
- Body Shield Assembly is tightly secured in Balancer Connector, and (4) screws are installed and torqued to 55 inch-pounds
- Body Shield hangs vertically (not tilted).
- Balancer, Linear bearing, Rotational bearing, and Boom operate freely and smoothly throughout range of motion.
- Boom Arm does not lock in a position parallel with the Rail Assembly.
- Balancer vertical travel operates freely and smoothly throughout range of motion.
- Body Shield is stationary when adjusted (no drift up or down).
- Zero-Gravity is located in the operating suite per TIDI Products Placement Plan specifications.
- Zero-Gravity has been wiped clean of any installation dirt and or oils according to User's Guide (TIDI Products document 84000). Do not clean acrylic glass.

Note: Alternative fasteners approved for use by engineer of record are recorded on sheet 2 of this 3-sheet form.

Zero-Gravity Monorail Installation Checklist

ZGCM-HSA

NOTE: THIS IS SHEET 1 OF A 3-SHEET FORM

I hereby certify that this equipment/application/system is functionally acceptable at the current time and the following items have been checked and verified:

- (10) Toe Clamp mounting bolts (5/8-11 x 2-3/4 inches long) are installed and torqued to 100 foot-pounds (135 Newton-meters), or grade A490, or better, approved by the facility engineer of record and specified below.
- (10) Toe Clamp covers are securely snapped in place.
- (12) Carriage Plate to Drop Tube screws (M8 X 30mm) are installed and torqued to 350 inch-pounds (29 foot-pounds) (39 N-m).
- (8) Swivel Boom Assembly to Boom Arm Assembly mounting screws (5/16"-18 X 1") are installed and torqued to 425 inch-pounds (35 foot-pounds) (48 Newton-meters).
- Carriage Cover is installed, and the mounting screws are tightened securely.
- Confirm User's manual and Installation Guides are available in suite. If not, contact TIDI Products Sales at +1.920.751.4300. Hardcopies are supplied with each unit.
- (2) End Stop Cap shoulder bolts (5/16-18 x 2-3/4 inches long) on each end of the Boom are installed and tight.
- Body Shield Assembly is tightly secured in Balancer Connector, and (4) screws are installed and torqued to 55 inch-pounds.
- Body Shield hangs vertically (not tilted).
- Balancer, Linear bearing, Rotational bearing, and Boom operate freely and smoothly throughout range of motion.
- Balancer vertical travel operates freely and smoothly throughout range of motion.
- Body Shield is stationary when adjusted (no drift up or down).
- Zero-Gravity is located in the operating suite per TIDI Products Placement Plan specifications.
- Zero-Gravity has been wiped clean of any installation dirt and or oils according to User's Guide (TIDI Products document 84000). Do not clean acrylic glass.

Note: Alternative fasteners approved for use by engineer of record are recorded on sheet 2 of this 3-sheet form.

NOTE: THIS IS SHEET 2 OF A 3-SHEET FORM

Please list notes regarding the installation of the system, including all A490 grade, or better, fasteners approved for use by engineer of record, location of use on the system, and torque value.

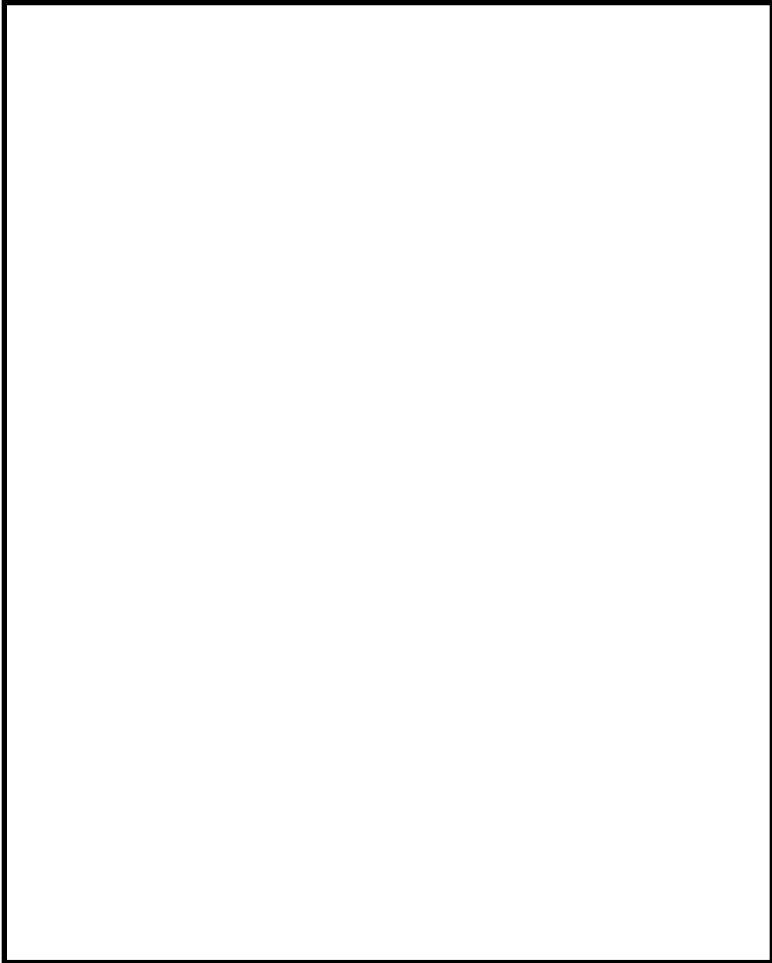
A large, empty rectangular box with a black border, intended for the user to provide installation notes as specified in the text above.

Engineer of record Name

Zero-Gravity® Radiation Protection System Installation Guide

NOTE: THIS IS SHEET 3 OF A 3-SHEET FORM

Part #: _____

Model Description: _____

Serial #: _____

Other: _____

Facility Name: _____

Installation Address: _____

I, _____,
TIDI Products-authorized installer, hereby certify that this Equipment/Application/
System is functionally acceptable at the current time.

I, _____, (name of facility representative)
_____, (title of facility representative)
hereby certify that this Equipment/Application/System is functionally acceptable at
the current time.

Installer Signature: _____

Installer Name: _____

Date of Acceptance: _____

Telephone: _____

Installer Email Address: _____

Facility Representative Signature

Date

Facility Representative Name

Index of Additional System Labels

Body Shield Labels

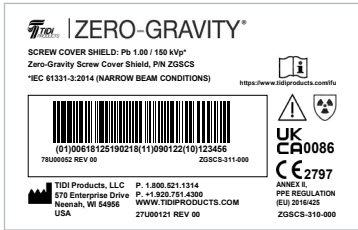

Screw Cover Shield System Label is used to define the Screw Cover:

- Cover (1.0) radiation protection in millimeters of lead equivalent per 150 kVp (Narrow Beam Conditions)
- Standards followed
- Contact information

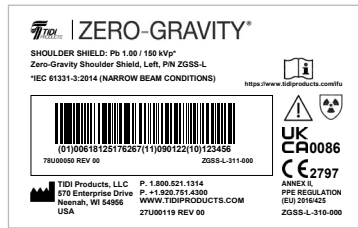

Shoulder Shield System Label is used to define the Left Shoulder Shield:

- Shoulder Shield (1.0) radiation protection in millimeters of lead equivalent per 150 kVp (Narrow Beam Conditions)
- Standards followed
- Contact information

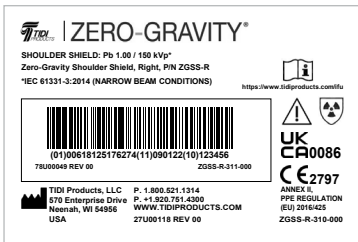

Shoulder Shield System Label is used to define the Right Shoulder Shield:

- Shoulder Shield (1.0) radiation protection in millimeters of lead equivalent per 150 kVp (Narrow Beam Conditions)
- Standards followed
- Contact information

Vest Labels



Write name of user on label.

Size **Extra Small**

Replacement Part Number:
ZGAV-XS

Contact Information
Standards followed

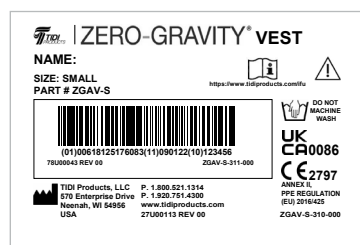

Write name of user on label.

Size **Small**

Replacement Part Number:
ZGAV-S

Contact Information
Standards followed



Write name of user on label.

Size **Medium**

Replacement Part Number:
ZGAV-M

Contact Information
Standards followed



Write name of user on label.

Size **Large**

Replacement Part Number:
ZGAV-L

Contact Information
Standards followed



Write name of user on label.

Size **Extra Large**

Replacement Part Number:
ZGAV-XL

Contact Information
Standards followed



Write name of user on label.

Size **3 Extra Large**

Replacement Part Number:
ZGAV-3XL

Contact Information
Standards followed

Limited Warranty

TIDI Products warrants to Customer that this product, manufactured for TIDI Products and sold to customer, will be free from defects in materials and workmanship for a period of one (1) year after delivery to Customer. This warranty shall not apply to any products, which have been subjected to misuse, improper installation or repair, alteration, neglect, accident, abnormal conditions of operation, or use under conditions other than those for which the products were designed.

EXCEPT FOR THE FOREGOING LIMITED WARRANTY, SELLER MAKES NO OTHER WARRANTIES, EITHER EXPRESSED OR IMPLIED, INCLUDING, WITHOUT LIMITATION, WARRANTIES OF FITNESS FOR A PARTICULAR PURPOSE OR OF MERCHANTABILITY.

Declarations of Conformity

The Zero-Gravity® Radiation Protection System Declarations of Conformity can be found at www.tidiproducts.com, and for additional information contact TIDI Products at 1.800.521.1314 or +1.920.751.4300.

NOTES

THIS PAGE IS INTENTIONALLY LEFT BLANK

Manufactured for:



Made in the
United States of America

CONTACT INFORMATION

Phone: 1.800.521.1314
+1.920.751.4300

United States Patents
7,608,847; 7,973,299;
8,198,616; 8,207,516;
8,558,204; 8,598,554 B2;
8,925,553; 8,933,426

For U.S. and Foreign Patent
information, see
[//go.tidiproducts.com/patents](http://go.tidiproducts.com/patents)
Additional Patents Pending

83000 Rev 01

